

PRODUCT AND PRICE CATALOGUE

METRIC MOTORS
GEARBOXES
COOLANT PUMPS

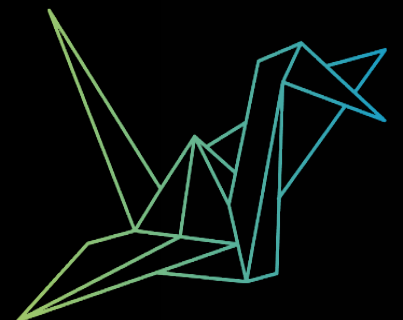
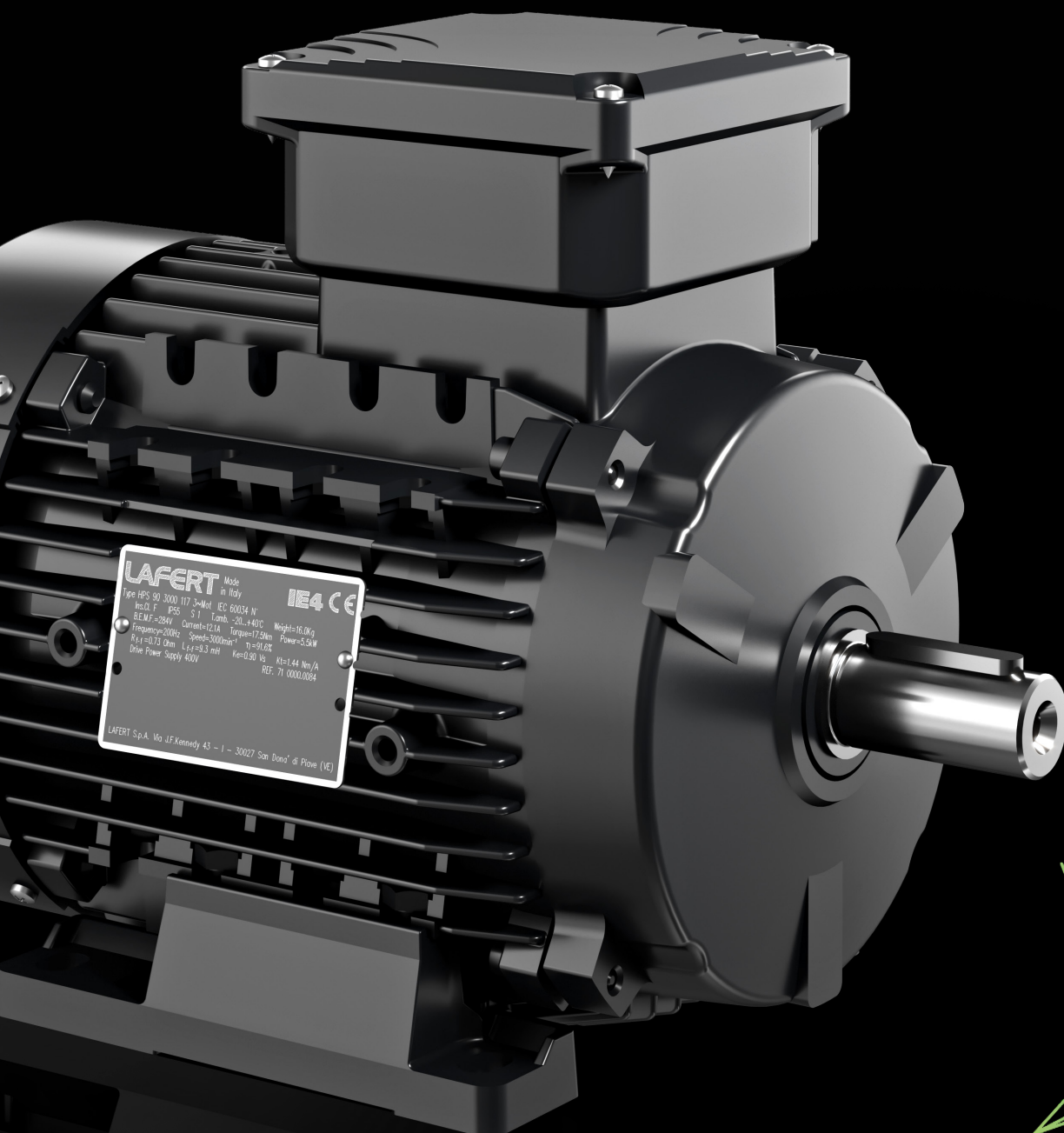

General Product Overview	4 & 5
Motors	
IE4 Three Phase/HPI/Combi - High Performance Permanent Magnet AC Motors, Packaged Drives & Brushless Servo Motors.....	6
HPS - High Performance Standalone Permanent Magnet AC Motors	7
AMPH / LAB - IE3 Premium Efficiency Motors (2 & 4 pole)	8
AMPH / LAB - IE3 Premium Efficiency Motors (6 & 8 pole)	9
ST / AM - Standard Efficiency Motors & 3-Phase Motor Parts Breakdown	10
FB - 2-Speed Motors	11
AMBZ - High Brake Torque Full Size Brake Motors (575V).....	12
AAF - High Brake Torque Full Size Brake Motors (230/460V).....	13
AAFB - 2-Speed High Brake Torque Full Size Brake Motors	14
AAF - High Brake Torque Full Size Brake Motors - Parts Breakdown.....	15
MS - Low Brake Torque Compact Brake Motors	16
MS - Low Brake Torque Compact Brake Motors - Parts Breakdown.....	17
Single Phase Motor - Connection Diagrams (Single & Dual Voltage)	17
LM / LME - Single Phase Motors (Single Voltage)	18
DVE - Single Phase Motors (Dual Voltage).....	19
LA - IP56 Stainless Steel Motors.....	20
LA - IP67 & IP69K Stainless Steel Motors.....	21
Cooling Fans & Fan Covers	22
Flanges.....	23
Dimensions for HPS - Permanent Magnet Synchronous Motors	24
Dimensions for DVE / LM(E) - Single Phase Motors (IM B3).....	25
Dimensions for AM / ST / FB - Three Phase Motors (IM B3).....	26
Dimensions for AMPH - Three Phase Premium Efficiency Motors (IM B3).....	27
Dimensions for AMBZ / AAF(B) / MS - Full Size & Compact Brake Motors (IM B3).....	28
Dimensions for Aluminum Frame (Single & 3-Phase) Motor Flanges (IM B14 & IM B5)	29
Dimensions for LAB / FB Motors (IM B3, IM B5, IM B35)	30
Explosion Proof Motors - MAK - Product Information.....	31 & 32
Explosion Proof Motors - MAK	33
Explosion Proof Motors - MAK - Dimensions (IM B3, IM B34, IM B35).....	34 & 35
Wiring Diagrams - ST / LAB / AM / AMPH / LA / FB / MS / AMFV	58
Pumps	
SPV / IMM / AP / MP - Immersion Type Pumps	36 & 37 & 38
SQ / AU - Side Mount / Self Priming Type Pumps.....	37 & 38
Gearboxes	
Featured SITI Gearboxes - Range	39
MI / MU - Right Angle Worm Gearboxes and Accessories.....	40
MI / MU - Right Angle Worm Gearboxes - Service Factors	41
I-MI - Ratings Table (Sizes 25-50).....	42
I-MI - Ratings Table (Sizes 60-110)	43
I-MI - Dimensions (Size 30).....	44
I-MI - Dimensions (Sizes 40-70).....	45
I-MI - Dimensions (Sizes 80-175).....	46
I-MI - Mounting Positions.....	47
U-MU - Ratings Table (Sizes 40-75).....	48
U-MU - Ratings Table (Sizes 90-110).....	49
U-MU - Mounting Positions	49
U-MU - Dimensions (Solid Input Shafts & Output Flanges)	50
P - Prestages and Bushings	51
MBH - Bevel Helical Gearboxes.....	52
MKF - Motovariator (Speed Variator) Gearboxes.....	52
MNHL(F) / NHL - Helical Inline Gearboxes - Product Information.....	53
MNHL(F) / NHL - Helical Inline - Ratings Table (Sizes 20-35).....	54
MNHL(F) / NHL - Helical Inline - Ratings Table (Sizes 40-70).....	55
MNHL(F) - Helical Inline - Dimensions	56
R - Bevel Gearboxes	57
NRG - Planetary Gearboxes	57
Terms And Conditions Of Sale/Warranty	59

GENERAL MECHANICAL CHARACTERISTICS

FRAME

The housing for frame sizes 56 & 63 as well as 180 - 315 feature motor pedestals that are integrally cast. Frame sizes 71 - 160 have pedestals that are removable. Pressure die cast aluminum frame sizes are from 56 - 160. Cast iron frame sizes are from 180 - 315.

FLANGES

Flange material is designed to match motor housing material (ie: cast aluminum or cast iron). For frame sizes 56 - 160, increased and reduced flanges are available in B14 (C flange) and B5 (D flange) styles.

BEARINGS

The bearings mounted on our motors are high quality Japanese made products. They are a rigid radial type with a single row of balls. The types used for different frame sizes are indicated in the table below. Roller bearings are used for frame sizes 315 - 4, 6 and 8 poles.

Aluminum Motors			Cast Iron (LAB) Motors		
Frame Size	Poles	DE / NDE	Frame Size	Poles	DE / NDE
56	2 - 4	6201-2Z	132 M	8	6308 C3
63	2 - 6	6202-2Z	160 M/L	2 - 8	6309 C3
71	2 - 8	6203-2Z	180 M/L	2 - 8	6311 C3
80	2 - 8	6204-2Z	200 L	2 - 8	6312 C3
90	2 - 8	6205-2Z	225 S/M	2 - 8	6313 C3
100	2 - 8	6206-2Z	250 M	2 - 6	6314 C3
112	2 - 8	6306-2Z	280 S/M	2	6314 C3
132	2 - 8	6208-2Z	280 S/M	4 - 6	6317 C3
160	2 - 8	6309-2Z	315 S/L	2	6317 C3
			315 S/L	4 - 8	NU319 / 6319 C3

Bearings of type designation "2Z" have two shields for each bearing which are pre-lubricated by the manufacturer. All bearings have clearance of (C3). Covers with grease lubricators can be supplied. All our bearings are pre-loaded axially with compensating rings of tempered steel. Motor frames 180 - 315 have re-greasable bearings; both drive and non-drive end shields are equipped with grease fittings.

COOLING

A fan with bi-directional blades supplies cooling. The fans are made of glass-reinforced polyethylene which is resistant to temperatures of up to 160° Celsius. Pressure die cast aluminum fans can be supplied on request.

FAN COVER

Frame sizes 56 - 112 are either a plastic/nylon composite, aluminum, or rolled steel. Frame sizes 132 - 200 and larger are rolled steel.

ROTORS

Rotors are "squirrel-cage" design, constructed of pressure die cast aluminum or aluminum alloy and dynamically balanced. Steel shafts (C40) can be either standard or specially made to your requirements. Standard motors have the shaft extending from one end of the motor only. Extensions from both ends can be supplied on request.

PAINT

All motors with the exception of explosion proof design (MAK) are normally painted with a semi-gloss black paint (RAL9005). Explosion proof motors are normally painted blue with RAL5010 which is an acid-protection coating for heavy duty applications.

NOISE

Motors are constructed to comply with international standards.

NOTE: All motors are Totally Enclosed Fan Cooled (TEFC) unless otherwise specified.

REQUIREMENTS

Lafert N.A recommends the use of filters and/or reactors when using a variable frequency drive to prevent failures due to spikes & surges. This is required for 575 V. Failure to install proper protection may void the motor warranty.

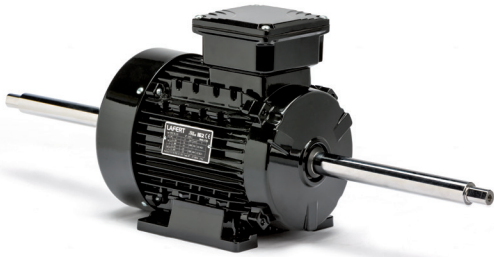

INGRESS PROTECTION RATINGS

The type of protection against accidental contact and/or the entry of water or foreign particles is denoted by IEC 34-5. The standard is composed of two letters followed by two numbers. See below for IP Rating code breakdown.

IP Ingress Protection

1st number From 0 to 6, The first number indicates complete protection against contact with live or moving parts inside the casing.

5 = Protection against harmful dust deposits; dust is not prevented from entering, but must not interfere with the proper functioning of the motor.

6 = Complete protection against contact; no ingress of dust.

2nd number From 0 to 9K, indicates progressively the level of protection against the entry of water.

4 = Protection against water sprayed on the motor from any direction.

5 = Protection against water jet from a nozzle onto the motor from any direction.

6 = Protection against heavy seas or water projected in powerful jets.

7 = Ingress of water in harmful quantity shall not be possible when the enclosure is immersed in water under defined conditions of pressure and time (up to 1 meter of submersion).

9K = Protection against close-range high pressure, high temperature spray downs.

Lafert NA stocks motors in: **IP54, IP55, IP56, IP67 & IP69K**

Available Features and Customization Capabilities:

Ingress Protection: IP54, IP55, IP56, IP65, IP67 & IP69K

Environmental: Tropicalized Windings

Mounting: F1, F2, F0, Basemount, B35, B5, B34, B14, NEMA C Face & Special Brackets

Flange Design: Increased or Reduction, Vertical or Horizontal

Drainage: Drain Holes, T-Valve Fittings

Mechanical Design:

- Special Shafts:
 - Non-Standard Length & Diameter
 - Multiple Steps
 - Drilled & Tapped or External Thread
 - Double Shafted
 - Hollow Shaft
- Modified Flange Builds

Electrical Design:

- Low Voltages: 42/72V, Three Phase
- High Voltages: 690V, 60Hz, Three Phase
- 2 Speed: 2/8, 2/12, 4/16, 8/16 Poles
- Multi Speed: 2/4-8 (Three Speed), 4/8-6/12 Poles (Four Speed)
- Single Phase Motor Designs
- Specialized Connection Requirements
- AC & DC Brake Coil Voltages

Thermal Protection | Rain & Lint Covers | Encoder Mounting Options | Special Application Bearings

NEW - IE4 THREE-PHASE MOTORS

FIRST IN ENERGY SAVINGS

SUPER PREMIUM EFFICIENCY IE4
ASYNCHRONOUS INDUCTION MOTORS

1 - 20 HP

FRAME SIZE:

IEC 80 - 160

NEMA 56 - 254/256



HP Combi - High Performance Motor and Drive Package

HP Combi is a range of highly efficient motor and variable frequency drive (VFD) packaged solutions which combine industry-leading permanent magnet (PM) synchronous motor technology from Lafert with dedicated drive platforms engineered to deliver maximum energy cost savings and system performance for three application categories – pumps and fans (Combi Flow), automation and motion (Combi Plus) and general purpose (Combi Smart).

- Optimized for Increased System Efficiency Available up to 50 HP
- Plug & Play Solution Fully Dimensioned and Configured According to Customer Needs
- Advanced Control Electronics for Easy Commissioning, Control and Service
- IP66 / NEMA 4X outdoor
- Precise Speed Control

Designed for both variable torque applications, typically in HVAC, and for constant torque applications such as material handling, air compressors and vacuum pumps.



HP Integral - High Performance Integrated Permanent Magnet AC Motors with Frequency Drive

The HPI Series combines high performance HPS Series permanent magnet motors with variable frequency drives (VFD) optimized to produce a seamlessly integrated motor and drive solution. The on-board Lafert drive technology and control interface deliver optimized system performance and energy efficiency, without costly and time-consuming integration of discrete motors and drives.

- Space & Weight Savings up to 50% Relative to Equivalent EISA Premium Efficient Motors
- Includes IE4/IE5 "Super/Ultra" Premium Efficient HPS Series Motor
- Design eliminates enclosure requirement for frequency drive
- High Performance Sensorless AC Vector Control
- On-board Digital Analog I/O & Communications (Modbus RTU, RS 232, CANopen)
- Optimized for HVACR Applications

The HPI Series is available to equipment manufacturers for high volume applications (>1,000 units/year). Lafert offers HPI Series products with the option and capability to customize the control, electrical and mechanical design to customer specification. Please visit the Lafert North America website or contact our Outside Sales team for more information.

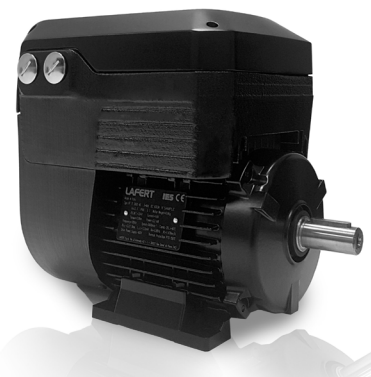

Lafert Brushless Servo Motors

Industry-leading Lafert expertise in production and design of permanent magnet motor technology has its foundation in twenty-five years of brushless servo motor manufacturing. A complete range of AC servo motors are manufactured to customer specifications at our Italian facility for applications such as material handling, packaging, precision manufacture and robot applications.

- Standard Range Includes Rated Torque (0.25 - 390+ Nm) & speed (0 - 6000+ rpm)
- Available Sensorless or with Resolver, Absolute or Incremental Encoder
- High Overload, Dynamic Performance, Power Density
- Forced Ventilation (Fan Cooled) & Brake Motor Executions
- Torque Motor ("pancake") Design for Direct-Drive Applications
- Standard or Optional Marks and Approvals Include CE, UL & ATEX Zone 2, 2 (Hazardous Location)

Lafert North America provides replacement support for current and legacy Lafert brushless servo motors.

Contact a Lafert sales representative for new servo motor applications.



HPS - High Performance Standalone Permanent Magnet AC Motors



IE4/IE5 Efficient Motor Solution for HVAC and Demanding Applications

Standard Range Covers (0.25 – 37) kW and (1800, 3600, 4500) RPM

- Super and Ultra Premium IE4/IE5 Energy Efficient as per IEC TS 60034-30-2:2016
- To Accommodate High Torque Output: Frames 71, 90 & 160 Have O/S DE & NDE Bearings. Frames 112 & 132 Have O/S DE Bearings & Standard NDE Bearings
- Class F (155°C) Insulation, Class B (80°C) Thermal Rise
- Foot (IM B3), Flange (IM B5 or IM B14, Metric or NEMA) Mounting (removable feet)
- IP55 Environmental Rating • Totally Enclosed Fan Cooled (TEFC)
- Designed for Sensorless Control (no encoder required)

HPS Series motors require a frequency drive to start/run and cannot be started across-the-line.

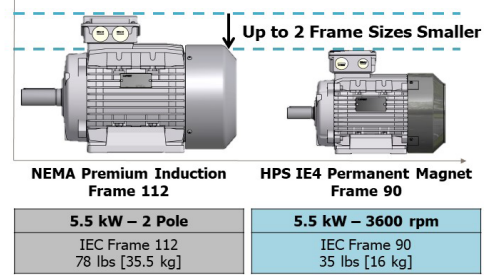

HPS Series IE4 - 3600 RPM - Values @ 460V

Dimensions: Page 24

Part Number	NEMA C-Flange Mount	Rated Power	Rated Torque	Peak Torque	Voltage Constant	Torque Constant Speed	BEMF at Rated Speed	Rated Current	Efficiency HPS	Weight
		Pn kW	Mn Nm	Mpk Nm	Ke Vs	Kt Nm/A	En Vrs	In Arms	η %	lbs
HPS56 3600 4	-	0.25	0.70	2.0	0.90	1.56	339	0.4	71.5%	6
HPS56 3600 6	-	0.37	1.00	2.9	0.90	1.56	339	0.6	75.6%	6
HPS56 3600 10	-	0.55	1.50	4.4	0.90	1.56	339	1.0	79.3%	6
HPS56 3600 13	-	0.75	2.00	6.0	0.90	1.56	339	1.3	81.5%	7
HPS71 3600 13	56	0.75	2.00	6.0	0.90	1.56	339	1.3	81.5%	11
HPS71 3600 19	56	1.10	2.90	8.8	0.90	1.56	339	1.9	83.3%	12
HPS71 3600 26	56	1.50	4.00	11.9	0.90	1.56	339	2.6	84.8%	13
HPS71 3600 37	56	2.20	5.80	17.5	0.90	1.56	339	3.7	86.4%	15
HPS90 3600 37 (S-L)	143/145	2.20	5.80	17.5	0.90	1.56	339	3.7	86.4%	22
HPS90 3600 51 (S-L)	143/145	3.00	8.00	23.9	0.90	1.56	339	5.1	87.7%	26
HPS90 3600 68 (S-L)	143/145	4.00	10.60	31.8	0.90	1.56	339	6.8	88.7%	31
HPS90 3600 94 (S-L)	143/145	5.50	14.60	43.8	0.90	1.56	339	9.4	89.7%	35
HPS112 3600 94 (M)	182/184	5.50	14.60	43.8	0.90	1.56	339	9.4	89.7%	51
HPS112 3600 128 (M)	182/184	7.50	19.90	59.7	0.90	1.56	339	12.8	90.6%	57
HPS112 3600 187 (M)	182/184	11.00	29.20	87.5	0.90	1.56	339	18.7	91.6%	66
HPS112 3600 255 (M)	182/184	15.00	39.80	119.4	0.90	1.56	339	25.5	92.4%	73
HPS132 3600 255 (M)	213/215	15.00	39.80	119.4	0.90	1.56	339	25.5	92.4%	112
HPS132 3600 315 (XL)	213/215	18.50	49.10	147.2	0.90	1.56	339	31.5	92.8%	128
HPS132 3600 375 (XXL)	213/215	22.00	58.40	175.1	0.90	1.56	339	37.5	93.2%	143
HPS132 3600 511 (XXL)	213/215	30.00	79.60	238.7	0.90	1.56	339	51.1	93.7%	159
HPS160 3600 511 (L)	-	30.00	79.6	199	0.90	1.56	339	51.1	93.7%	176
HPS 160 3600 629 (L)	-	37.00	98	245	0.90	1.56	339	62.9	94.1%	187

HPS Series - 1800 RPM - Values @ 460V

Part Number	NEMA C-Flange Mount	Rated Power	Rated Torque	Peak Torque	Voltage Constant	Torque Constant Speed	BEMF at Rated Speed	Rated Current	Efficiency HPS	Weight
		Pn kW	Mn Nm	Mpk Nm	Ke Vs	Kt Nm/A	En Vrs	In Arms	η %	lbs
HPS56 1800 3	-	0.18	1.00	2.9	1.80	3.1	339	0.3	72.0%	6
HPS56 1800 4	-	0.25	1.30	4.0	1.80	3.1	339	0.4	75.4%	7
HPS56 1800 6	-	0.37	2.0	5.9	1.80	3.1	339	0.6	78.9%	7
HPS71 1800 9	56	0.55	2.90	8.8	1.80	3.1	339	0.9	81.9%	11
HPS71 1800 13	56	0.75	4.00	11.9	1.80	3.1	339	1.3	83.9%	12
HPS71 1800 19	56	1.10	5.80	17.5	1.80	3.1	339	1.9	85.6%	14
HPS71 1800 26	56	1.50	8.00	23.9	1.80	3.1	339	2.6	86.7%	15
HPS90 1800 26 (S-L)	143/145	1.50	8.00	23.9	1.80	3.1	339	2.6	86.7%	22
HPS90 1800 38 (S-L)	143/145	2.20	11.70	35.0	1.80	3.1	339	3.8	88.1%	26
HPS90 1800 51 (S-L)	143/145	3.00	15.90	47.7	1.80	3.1	339	5.1	89.1%	31
HPS90 1800 68 (S-L)	143/145	4.00	21.20	63.7	1.80	3.1	339	6.8	89.9%	37
HPS112 1800 68 (M)	182/184	4.00	21.20	63.7	1.80	3.1	339	6.8	89.9%	51
HPS112 1800 94 (M)	182/184	5.50	29.20	87.5	1.80	3.1	339	9.4	90.8%	57
HPS112 1800 128 (M)	182/184	7.50	39.80	119.4	1.80	3.1	339	12.8	91.6%	66
HPS112 1800 187 (XL)	182/184	11.00	58.40	175.1	1.80	3.1	339	18.7	92.0%	73
HPS132 1800 187 (M)	213/215	11.00	58.40	175.1	1.80	3.1	339	18.7	92.4%	112
HPS132 1800 255 (XXL)	213/215	15.00	79.60	238.7	1.80	3.1	339	25.5	93.0%	128
HPS132 1800 315 (XXL)	213/215	18.50	98.10	294.4	1.80	3.1	339	31.5	93.4%	143
HPS160 1800 186 (M)	-	11.00	58.00	146.0	1.80	3.1	339	18.6	92.4%	143
HPS160 1800 257 (M)	-	15.00	80.00	199.0	1.80	3.1	339	25.7	93.0%	154
HPS160 1800 314 (M)	-	18.50	98.00	245.0	1.80	3.1	339	31.4	93.4%	154
HPS160 1800 375 (L)	-	22.00	117.00	292.0	1.80	3.1	339	37.5	93.7%	176
HPS160 1800 510 (L)	-	30.00	159.00	398.0	1.80	3.1	339	51.0	94.2%	209

AMPH / LAB - IE3 Premium Efficiency Motors



3-Phase: 60Hz Standard

1.15 Service Factor (SF) • 208-230/460V 9 Leads • 333/575V 6 Leads

Frame Sizes 100 and Above in 575/990V 6 Leads • Frame Sizes 132 to 315 in 460/796V 6 Leads

Threaded Hole Output Shaft (Standard) • Squirrel Cage • Class F • TEFC • IP55 • IEC - CEI - UNEL MEC

Compliant with EISA Regulations & NRCAN Approved

AMPH (cURus approved) - 6:1 CT Turn Down - F2 Lead Box (F0 or F1 Available) - CC#: 046B

LAB (CSA Energy Verified) - 10:1 CT Turn Down - TEFC - PTC - Cast Based (F0 Lead Box, Non-Removable Feet) - ExNa



Filter Requirements Page 4

AMPH Dimensions (Frames 80 to 160): Pages 27 & 29

LAB Cast Iron Dimensions (Frames 132 to 315): Page 30

2 POLE - 3600 RPM

Part Number	Output Power		Speed Min ⁻¹	Torque Nm	EFF. 100%	Full Load Amps		Weight (lbs)	Price (\$)
	kW	HP				460 V	575 V		
AMPH 80Z AA2	0.75	1.00	3525	2.00	85.0	1.50	1.20	21	\$832
AMPH 80Z BA2	1.10	1.50	3490	3.00	85.4	2.00	1.60	25	\$911
AMPH 80Z CA2	1.50	2.00	3460	4.10	85.5	2.80	2.20	30	\$941
AMPH 90S AA2 ●	1.50	2.00	3515	4.10	85.5	2.80	2.20	37	\$1,184
AMPH 90L BA2 ●	2.20	3.00	3480	6.00	86.5	3.80	3.00	41	\$1,550
AMPH 90L DA2 ●	3.00	4.00	3510	8.20	88.5	5.30	4.20	45	\$1,603
AMPH 100L AA2	3.00	4.00	3515	8.20	88.5	4.90	3.90	52	\$1,704
AMPH 100L CA2	4.00	5.50	3530	10.80	88.5	7.40	5.90	59	\$2,005
AMPH 112M BA2	4.00	5.50	3520	10.90	88.5	6.20	5.00	81	\$2,196
AMPH 112M CA2	5.50	7.50	3530	14.90	89.5	8.90	7.10	81	\$2,755
AMPH 112M DA2	7.50	10.00	3530	20.30	90.2	11.90	9.50	90	\$2,759
AMPH 132S ZA2	5.50	7.50	3540	14.80	89.5	8.80	7.00	93	\$2,891
AMPH 132S TA2	7.50	10.00	3540	20.20	90.2	12.00	9.60	106	\$3,605
AMPH 132M TA2	9.20	12.40	3545	24.80	90.2	14.50	11.60	111	\$4,092
AMPH 132M RA2	11.00	15.00	3535	29.70	91.0	17.70	14.20	133	\$4,414
AMPH 132M ZA2	15.00	20.00	3530	40.60	91.0	23.50	18.80	150	\$5,220
AMPH 160M YA2	11.00	15.00	3550	29.60	91.0	17.00	13.60	199	\$4,579
AMPH 160M ZA2	15.00	20.00	3555	40.30	91.0	23.40	18.70	203	\$6,030
AMPH 160L ZA2 *	18.50	25.00	3555	49.70	91.7	31.00	24.80	239	\$7,133
AMPH 160L TA2 *	22.00	30.00	3540	59.30	91.7	35.80	28.60	239	\$7,811
LAB 180M E2	22.00	30.00	3560	60.04	91.7	34.04	27.23	426	\$5,438
LAB 200L D2	30.00	40.00	3570	79.82	92.4	45.04	36.03	527	\$7,777
LAB 200L E2	37.00	50.00	3570	99.78	93.0	55.93	44.75	554	\$8,485
LAB 225M E2	45.00	60.00	3580	119.40	93.6	66.69	53.35	710	\$10,526
LAB 250M E2	55.00	75.00	3580	149.25	93.6	83.36	66.69	904	\$13,084
LAB 280S D2	75.00	100.00	3580	199.00	94.1	110.56	88.45	1210	\$15,965
LAB 280M E2	90.00	125.00	3580	248.75	95.0	136.89	109.51	1334	\$18,138
LAB 315S D2	110.00	150.00	3580	298.50	95.0	164.27	131.42	1850	\$32,723
LAB 315L D2	150.00	200.00	3580	398.01	95.4	218.11	174.49	2154	\$35,488

4 POLE - 1800 RPM

Part Number	Output Power		Speed Min ⁻¹	Torque Nm	EFF. 100%	Full Load Amps		Weight (lbs)	Price (\$)
	kW	HP				460 V	575 V		
AMPH 80Z AA4	0.75	1.00	1740	4.10	85.5	1.45	1.20	24	\$996
AMPH 90S AA4 ●	1.10	1.50	1745	6.00	86.5	2.20	1.80	42	\$1,153
AMPH 90L BA4 ●	1.50	2.00	1735	8.30	86.5	2.90	2.30	42	\$1,306
AMPH 90L CA4 ●	1.80	2.40	1730	9.90	86.5	3.80	3.00	42	\$1,485
AMPH 100L AA4 +	2.20	3.00	1760	11.90	89.5	3.80	3.00	55	\$1,731
AMPH 100L BA4 +	3.00	4.00	1765	16.20	89.5	5.30	4.20	70	\$1,983
AMPH 112M BA4	4.00	5.50	1760	21.70	89.5	6.90	5.50	79	\$2,220
AMPH 132S AA4	5.50	7.50	1770	29.70	91.7	9.00	7.20	132	\$3,107
AMPH 132M BA4	7.50	10.00	1765	40.50	91.7	12.50	10.40	143	\$3,547
AMPH 132M CA4	9.20	12.40	1765	49.80	91.7	15.20	13.80	156	\$4,203
AMPH 132M DA4	11.00	15.00	1770	59.70	92.4	18.50	14.80	170	\$4,579
AMPH 160M AA4	11.00	15.00	1770	58.30	92.4	18.60	15.00	230	\$5,429
AMPH 160L BA4	15.00	20.00	1770	80.00	93.0	24.80	19.80	272	\$7,044
AMPH 160L CA4	18.50	25.00	1770	99.80	93.6	32.50	26.00	243	\$7,572
AMPH 160L DA4	22.00	30.00	1770	118.60	93.6	35.60	28.50	298	\$8,122
LAB 180M D4	18.50	25.00	1770	100.63	93.6	29.77	23.82	417	\$5,309
LAB 180L E4	22.00	30.00	1770	120.75	93.6	37.51	30.01	452	\$5,675
LAB 200L D4	30.00	40.00	1770	161.00	94.1	49.75	39.80	564	\$7,300
LAB 225S D4	37.00	50.00	1770	201.25	94.5	57.61	46.09	680	\$8,952
LAB 225M E4	45.00	60.00	1770	241.50	95.0	68.76	55.01	736	\$10,829
LAB 250M E4	55.00	75.00	1770	301.88	95.4	86.60	69.28	913	\$13,384
LAB 280S D4	75.00	100.00	1780	400.24	95.4	115.47	92.38	1277	\$17,100
LAB 280M E4	90.00	125.00	1780	500.30	95.4	142.66	114.13	1400	\$19,109
LAB 315S D4	110.00	150.00	1780	600.36	95.8	174.53	139.63	1880	\$32,723
LAB 315L D4	150.00	200.00	1780	800.48	96.2	231.74	185.40	2220	\$35,488

● S/L dual set of holes on base (actual frame is 90L)

+ Special flange required (H4)

* △△/△ internal connection AMPH 9 lead hook up at 230/460V YY/Y connection, (except for 2 pole 160L - △△/△)

AMPH frame sizes from 80 to 160 have removable feet

LAB cast iron construction has non-removable feet

AMPH / LAB - IE3 Premium Efficiency Motors



3-Phase: 60Hz Standard

1.15 Service Factor (SF) • 208-230/460V 9 Leads • 333/575V 6 Leads

Frame Sizes 100 and Above in 575/990V 6 Leads • Frame Sizes 132 to 315 in 460/796V 6 Leads

Threaded Hole Output Shaft (Standard) • Squirrel Cage • Class F • TEFC • IP55 • IEC - CEI - UNEL MEC

Compliant with EISA Regulations & NRCAN Approved

AMPH (cURus approved) - 6:1 CT Turn Down - F2 Lead Box (F0 or F1 Available) - CC#: 046B

LAB (CSA Energy Verified) - 10:1 CT Turn Down - TEFC - PTC Included - Cast Based (F0 Lead Box, Non-Removable Feet) - ExNa



Filter Requirements Page 4

AMPH Dimensions (Frames 90 to 160): Pages 27 & 29

LAB Cast Iron Dimensions (Frames 132 to 315): Page 30

6 POLE - 1200 RPM

Part Number	Output Power		Speed Min ⁻¹	Torque Nm	EFF 100%	Full Load Amps		Weight (lbs)	Price (\$)
	kW	HP				460 V	575 V		
AMPH 90S AA6 [Ⓞ]	0.75	1.00	1155	6.2	82.5	2.05	1.65	41	\$1,419
AMPH 100L AA6 +	1.10	1.50	1175	8.9	87.5	2.50	2.00	64	\$2,047
AMPH 112M AA6	1.10	1.50	1180	8.9	87.5	2.50	2.00	78	\$2,416
AMPH 112M BA6	1.50	2.00	1180	12.1	88.5	3.50	2.80	83	\$2,699
AMPH 112M CA6	1.80	2.40	1170	14.7	88.5	3.90	3.10	83	\$3,417
AMPH 132S AA6	2.20	3.00	1175	17.9	89.5	4.70	3.80	105	\$3,348
AMPH 132S BA6	3.00	4.00	1175	24.4	89.5	6.40	5.10	108	\$3,671
AMPH 132M CA6	4.00	5.50	1175	32.5	89.5	7.90	6.30	113	\$4,236
AMPH 160M AA6	5.50	7.50	1180	44.5	91.0	9.80	7.80	189	\$5,780
AMPH 160M BA6	7.50	10.00	1180	60.7	91.0	13.60	10.90	234	\$6,540
AMPH 160L CA6	9.20	12.40	1175	74.8	91.0	16.40	13.10	257	\$7,524

[Ⓞ] S/L dual set of holes on base (actual frame is 90L)

AMPH frame sizes from 90 to 160 have removable feet.

+ Special flange required (H4)

Select AMPH sizes are available with dual mounting holes on the base.

9 lead hook up at 230/460V YYY connection (except for 2 pole 160L - $\Delta\Delta/\Delta$).

6 POLE - 1200 RPM

Part Number	Output Power		Speed Min ⁻¹	Torque Nm	EFF 100%	Full Load Amps		Weight (lbs)	Price (\$)
	kW	HP				460 V	575 V		
LAB 180L D6	15.00	20.00	1180	120.75	91.7	25.53	20.42	408	\$5,711
LAB 200L D6	18.50	25.00	1160	153.54	93.0	31.46	25.17	542	\$7,219
LAB 200L E6	22.00	30.00	1160	184.25	93.0	37.76	30.20	565	\$7,845
LAB 225M D6	30.00	40.00	1160	245.67	94.1	49.75	39.80	710	\$10,182
LAB 250M E6	37.00	50.00	1160	307.08	94.1	62.19	49.75	842	\$12,488
LAB 280S D6	45.00	60.00	1160	368.50	94.5	74.31	59.45	1090	\$15,993
LAB 280M E6	55.00	75.00	1190	449.01	94.5	92.89	74.31	1180	\$17,803
LAB 315L D6	110.00	150.00	1170	598.68	95.8	174.70	139.39	2180	\$38,031

8 POLE - 900 RPM

Part Number	Output Power		Speed Min ⁻¹	Torque Nm	EFF 100%	Full Load Amps		Weight (lbs)	Price (\$)
	kW	HP				460 V	575 V		
LAB 132M ZA8	2.20	3.00	870	24.57	85.5	4.63	3.70	128	\$2,153
LAB 132M TA8	3.00	4.00	870	32.76	86.5	6.10	4.88	143	\$2,684
LAB 160M YA8	3.70	5.00	870	40.94	86.5	7.52	6.01	210	\$3,576
LAB 160M ZA8	5.50	7.50	870	61.42	86.5	11.28	9.02	240	\$4,002
LAB 160L ZA8	7.50	10.00	870	81.89	89.5	14.53	11.62	287	\$4,637
LAB 180L E8	11.00	15.00	870	122.83	89.5	21.21	16.97	416	\$5,624
LAB 200L E8	15.00	20.00	870	163.78	90.2	27.68	22.15	443	\$7,783
LAB 200L D8	18.00	25.00	880	202.39	90.2	34.60	27.68	485	\$8,596
LAB 225S E8	22.00	30.00	880	242.87	91.7	40.31	32.24	595	\$10,358
LAB 225M E8	30.00	40.00	880	323.83	91.7	53.74	42.99	815	\$11,448

LAB cast iron construction has non-removable feet.

3-Phase: 60Hz standard

1.15 Service Factor (SF) • 208-230/460V - 333/575V • F2 Lead Box (F0 or F1 Available for Frame Sizes 71 and Above)

Dimensions: Pages 26 & 29

TEFC • IP55 • Squirrel Cage • Threaded Hole Output Shaft (Standard) • Class F • IEC - CEI - UNEL MEC

AM Motors (cURus approved)

ST Motors (CSA Approved)

3 Phase Motor Parts Breakdown

When inquiring or ordering spare parts, please supply the following information:

- Motor Type
- Designation of Spare Part
- Mounting Arrangement
- Motor Serial Number
- Date on Nameplate

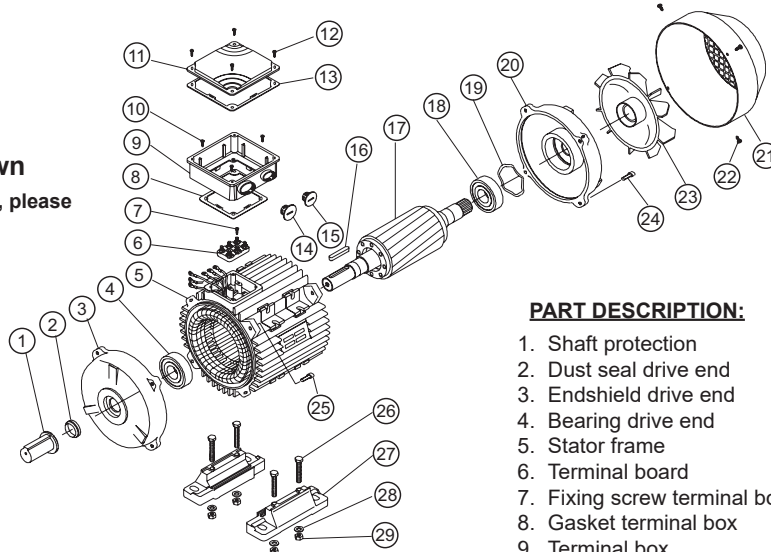

PART DESCRIPTION:

1. Shaft protection
2. Dust seal drive end
3. Endshield drive end
4. Bearing drive end
5. Stator frame
6. Terminal board
7. Fixing screw terminal board
8. Gasket terminal box
9. Terminal box
10. Fixing screw terminal box
11. Terminal box lid
12. Fixing screw terminal box lid
13. Gasket terminal box lid
14. Blank gland plug
15. Blank gland plug
16. Key
17. Rotor complete
18. Bearing non-drive end
19. Pre-load washer
20. Endshield non-drive end
21. Fan cover
22. Fixing screw fan cover
23. Fan
24. Fixing bolt endshield non-drive end
25. Fixing bolt endshield drive end
26. Fixing bolt motor feet
27. Motor feet
28. Fixing washer motor feet
29. Fixing nut motor feet

2 POLE - 3600 RPM

Part Number	HP	Full Load Amps		Torque Nm	Speed Min ⁻¹	Weight (lbs)	Price (\$)
		460 V	575 V				
ST 56 S2 *	0.18	0.40	0.29	0.39	3300	7	\$468
ST 63 C2 *	0.25	0.55	0.45	0.57	3120	8	\$471
ST 63 S2 *	0.35	0.75	0.60	0.75	3310	9	\$477
ST 63 L2 *	0.50	1.10	0.90	1.09	3265	10	\$493
ST 71 C2	0.50	0.95	0.75	1.08	3300	13	\$501
ST 71 S2	0.75	1.40	1.10	1.58	3380	14	\$508
ST 71 L2	1.00	1.85	1.50	2.15	3320	16	\$570

4 POLE - 1800 RPM

Part Number	HP	Full Load Amps		Torque Nm	Speed Min ⁻¹	Weight (lbs)	Price (\$)
		460 V	575 V				
ST 56 S4 *	0.12	0.40	0.29	0.55	1560	6	\$468
ST 63 C4 *	0.18	0.45	0.35	0.79	1630	7	\$471
ST 63 S4 *	0.25	0.60	0.50	1.12	1590	9	\$475
ST 63 A4 *	0.33	0.80	0.65	1.44	1630	9	\$477
ST 71 C4	0.35	0.85	0.65	1.56	1600	13	\$492
ST 71 S4	0.5	1.10	0.90	2.16	1650	13	\$499
AM 71 ZCA4	0.75	1.50	1.20	3.20	1670	16	\$560
ST 80 C4	0.75	1.50	1.20	3.18	1680	18	\$564

6 POLE - 1200 RPM

Part Number	HP	Full Load Amps		Torque Nm	Speed Min ⁻¹	Weight (lbs)	Price (\$)
		460 V	575 V				
ST 63 C6 *	0.12	0.55	0.45	0.87	980	10	\$739
ST 71 C6	0.25	0.80	0.65	1.70	1050	14	\$763
ST 71 S6	0.35	1.00	0.80	2.44	1020	15	\$772
ST 80 C6	0.50	1.15	0.90	3.27	1090	18	\$793
ST 80 S6	0.75	1.60	1.30	4.90	1090	21	\$859

8 POLE - 900 RPM

Part Number	HP	Full Load Amps		Torque Nm	Speed Min ⁻¹	Weight (lbs)	Price (\$)
		460 V	575 V				
ST 71 C8	0.20	0.60	0.50	1.87	760	13	\$897
ST 80 C8	0.35	1.00	0.80	3.08	810	18	\$1,100
ST 90S C8 ●	0.50	1.60	1.25	4.40	810	25	\$1,313
ST 90L S8 ●	0.75	2.30	1.85	6.60	810	33	\$1,476

* Non-removable feet - side mount only (F2 standard/ F1 upon request)

● S/L dual set of holes on base (actual frame is 90L)

Frame sizes from 71 to 90 have removable feet.

3-Phase: 60Hz standard

1.0 Service Factor (SF) • 230V, 460V or 575V • Constant Torque • Threaded Hole Output Shaft

TEFC • Squirrel Cage • Class F • IP55 - IEC - CEI - UNEL MEC

Frame Sizes 71-160: F2 Lead Box (F0 or F1 Available)

Frame Sizes 180-315: F0 Lead Box (Cast based, Non-Removable Feet)

Dimensions (Frames 63 to 160): Pages 26 & 29

Dimensions (Frames 180 to 315 - same as LAB series): Page 30

2/4 POLE - 3600/1800 RPM - 1 WINDING

Part Number	HP	Weight (lbs)	FULL LOAD AMPS		Price (\$)
			460 V	575 V	
FB 63 S2/4 *	0.40/0.27	10	0.80/0.62	0.64/0.50	\$978
FB 71 C2/4	0.60/0.40	17	1.36/0.96	1.09/0.77	\$1,154
FB 80 C2/4	0.80/0.60	19	1.44/1.12	1.15/0.90	\$1,300
FB 80 S2/4	1.00/0.75	25	1.76/1.44	1.41/1.15	\$1,385
FB 80 L2/4	1.50/1.10	32	2.48/1.92	1.98/1.54	\$1,468
FB 90L C2/4 ●	2.10/1.60	34	3.12/2.72	2.50/2.18	\$1,910
FB 90L S2/4 ●	2.60/1.90	38	3.60/2.88	2.88/2.30	\$2,081
FB 100L C2/4	3.40/2.50	47	4.72/3.60	3.78/2.88	\$2,478
FB 100L L2/4	4.00/3.00	50	6.16/4.64	4.93/3.71	\$2,509
FB 100L S2/4	4.50/3.50	51	6.56/5.28	5.25/4.22	\$2,914
FB 112M C2/4	6.00/4.50	80	8.16/5.76	6.53/4.61	\$4,027
FB 132S ZA2/4	8.00/6.40	101	9.60/9.60	7.68/7.68	\$5,419
FB 132M ZA2/4	11.00/9.00	121	13.60/12.80	10.88/10.24	\$6,335
FB 160M ZA2/4	14.50/11.70	192	18.00/17.60	14.40/14.08	\$9,826
FB 160L ZA2/4	22.50/17.00	225	24.80/22.80	19.84/18.24	\$14,957
FB 180M ZA2/4	26.50/20.00	287			\$16,078
FB 180L ZA2/4	31.00/24.00	309			\$19,079
FB 200L P2/4	39.00/32.50	507			\$25,689
FB 200L R2/4	45.00/35.00	562			\$27,192
FB 225S P2/4	52.00/40.00	716			\$31,449
FB 225M P2/4	63.00/46.00	728			\$35,525
FB 250M P2/4	79.00/68.00	1025	INQUIRE		\$46,588
FB 280S V2/4	98.00/82.00	1279			\$63,205
FB 280M V2/4	114.00/95.00	1367			\$75,429
FB 315S ZE2/4	156.00/116.00	1896			\$90,576
FB 315M ZE2/4	170.00/136.00	2073			\$111,244
FB 315L ZE2/4	204.00/163.00	2470			\$119,980

4/8 POLE - 1800/900 RPM - 1 WINDING

Part Number	HP	Weight (lbs)	FULL LOAD AMPS		Price (\$)
			460 V	575 V	
FB 71 C4/8	0.35/0.18	15	0.56/0.64	0.45/0.51	\$1,359
FB 80 C4/8	0.50/0.25	17	0.83/0.63	0.66/0.50	\$1,511
FB 80 S4/8	0.70/0.35	20	1.12/1.04	0.90/0.83	\$1,594
FB 90S C4/8 ●	1.00/0.50	30	1.68/1.44	1.34/1.15	\$1,974
FB 90L S4/8 ●	1.30/0.70	35	1.92/1.76	1.54/1.41	\$2,231
FB 100L C4/8	1.90/0.90	48	2.72/2.80	2.18/2.24	\$2,478
FB 100L S4/8	2.50/1.20	56	3.30/3.10	2.64/2.48	\$2,708
FB 112M C4/8	2.40/1.40	70	3.36/3.20	2.69/2.56	\$3,223
FB 112M S4/8	3.00/1.80	75	4.16/3.68	3.33/2.94	\$3,808
FB 132S ZA4/8	5.20/2.80	95	7.68/5.76	6.14/4.61	\$5,545
FB 132M ZA4/8	6.50/3.50	119	9.36/6.72	7.49/5.38	\$6,346
FB 132M L4/8	7.50/4.00	135	9.73/7.20	7.78/5.76	\$6,870
FB 160M C4/8	8.50/5.50	165	9.60/9.60	7.68/7.68	\$8,049
FB 160M YA4/8	10.00/5.50	185	13.20/11.36	10.56/9.09	\$9,786
FB 160M ZA4/8	12.20/7.00	198	16.80/14.40	13.44/11.52	\$12,382
FB 160L ZA4/8	17.00/10.00	220	18.40/18.40	14.72/14.72	\$14,854
FB 180L ZA4/8	24.00/15.00	331			\$20,780
FB 200L P4/8	31.00/20.00	485			\$26,354
FB 200LR4/8	39.00/24.00	562			\$32,548
FB 225S P4/8	43.00/28.00	684			\$35,572
FB 225M P4/8	50.00/35.00	695			\$41,592
FB 250M P4/8	63.00/43.00	1080	INQUIRE		\$51,834
FB 280S V4/8	82.00/60.00	1279			\$66,302
FB 280M V4/8	95.00/71.00	1367			\$82,885
FB 315S ZE4/8	136.00/82.00	1742			\$101,878
FB 315M ZE4/8	163.00/100.00	1896			\$129,607
FB 315L ZE4/8	200.00/120.00	2183			\$156,731

4/6 POLE - 1800/1200 RPM - 2 WINDING

Part Number	HP	Weight (lbs)	FULL LOAD AMPS		Price (\$)
			460 V	575 V	
FB 71 C4/6	0.35/0.25	16	0.64/0.56	0.51/0.45	\$1,491
FB 80 A4/6	0.50/0.35	18	0.84/0.80	0.67/0.64	\$1,721
FB 80 C4/6	0.75/0.50	22	1.28/1.12	1.02/0.90	\$1,831
FB 90L C4/6 ●	1.20/0.80	36	2.00/2.00	1.60/1.60	\$2,249
FB 100L L4/6	1.50/1.00	54	2.88/2.08	2.30/1.66	\$2,617
FB 100L C4/6	2.00/1.20	73	3.12/2.32	2.50/1.86	\$2,889
FB 112M C4/6	2.50/1.80	74	3.92/3.36	3.14/2.69	\$3,604
FB 112M S4/6	3.50/2.50	81	4.96/4.24	3.97/3.39	\$4,439
FB 132S ZA4/6	4.00/3.00	95	7.60/6.00	6.08/4.80	\$4,983
FB 132M ZA4/6	6.70/4.30	119	9.40/8.30	7.52/6.64	\$9,728
FB 160M YA4/6	10.00/6.80	185	13.20/9.60	10.56/7.68	\$10,708
FB 160M ZA4/6	12.20/8.00	198	18.40/13.60	14.72/10.88	\$12,179
FB 160L ZA4/6	16.00/11.00	220	19.20/18.40	15.36/14.72	\$16,689
FB 180L ZA4/6	22.50/15.00	331	INQUIRE	INQUIRE	\$21,357

6/8 POLE - 1200/900 RPM - 2 WINDING

Part Number	HP	Weight (lbs)	FULL LOAD AMPS		Price (\$)
			460 V	575 V	
FB 71 C6/8	0.30/0.15	16	0.70/0.46	0.56/0.37	\$1,554
FB 80 C6/8	0.50/0.25	21	1.09/0.72	0.87/0.58	\$2,055
FB 90L C6/8 ●	0.75/0.40	36	1.68/1.48	1.34/1.18	\$2,927
FB 100L C6/8	1.00/0.60	52	1.84/1.68	1.47/1.34	\$3,157
FB 112M C6/8	1.30/0.90	70	2.48/1.84	1.98/1.47	\$3,793
FB 112M S6/8	2.00/1.00	80	3.60/1.84	2.88/1.47	\$4,312
FB 132S ZA6/8	2.20/1.80	95	5.52/4.16	4.42/3.33	\$5,787
FB 132M ZA6/8	3.90/3.00	119	6.64/4.72	5.31/3.78	\$7,458
FB 160M YA6/8	5.50/4.00	185	9.20/6.32	7.36/5.06	\$9,716
FB 160M ZA6/8	7.50/5.50	198	12.16/9.60	9.73/7.68	\$12,339
FB 160L ZA6/8	10.00/7.50	220	14.40/11.60	11.52/9.28	\$13,677
FB 180L ZA6/8	15.00/11.50	331	INQUIRE	INQUIRE	\$19,287

* Non-removable feet - side mount only (F2 standard/ F1 upon request)
 ● S/L dual set of holes on base (actual frame is 90L)

2/8 POLE - 3600/900 RPM - 2 WINDING

Part Number	HP	Weight (lbs)	FULL LOAD AMPS		Price (\$)
			460 V	575 V	
FB 80 C2/8	0.50/0.15	21	1.04/0.56	0.83/0.45	\$2,072
FB 80 S2/8	0.75/0.15	26	1.12/0.67	0.90/0.54	\$2,233
FB 90L C2/8 ●	1.00/0.25	35	2.00/0.92	1.60/0.74	\$2,705
FB 90L S2/8 ●	1.50/0.40	43	2.64/1.20	2.11/0.96	\$2,961
FB 100L S2/8	2.00/0.50	45	2.80/1.60	2.24/1.28	\$3,204
FB 100L L2/8	2.50/0.60	45	3.44/1.76	2.75/1.41	\$3,762
FB 112M C2/8	2.50/1.45	78	4.00/2.96	3.2/2.37	\$4,439
FB 112M L2/8	3.00/0.75	79	4.40/1.60	3.52/1.28	\$4,762
FB 132S C2/8	4.00/1.00	81	6.90/4.00	5.52/3.2	\$5,793
FB 132M S2/8	6.00/1.50	94	7.60/5.60	6.08/4.48	\$7,461



Frame sizes from 71 to 160 have removable feet.

Custom 2-Speeds available in all frame sizes.

AMBZ - High Brake Torque Full Size Brake Motors (575V)



Self Braking - 3-Phase: 60 Hz standard - AC 6 Lead-Coil Brake

1.15 Service Factor (SF) • 333/575V • Brake Voltage Same as Motor Voltage • TEFC • Squirrel Cage • Class F

DC Brake Coil Available • Manual Release Key Optional (side of motor) • IP54

IEC • CEI • UNEL MEC • CuRus • S3 60% Duty Cycle • F2 Lead Box (F0 or F1 Available for Frame Sizes 71 and Above)

Dimensions: Pages 28 & 29

2 POLE - 3600 RPM

Part Number	HP	Full Load Amps 575 V	Torque Nm	Speed Min ⁻¹	Max Brake Torque (Nm)	Weight (lbs)	Price (\$)
AMBZ 63 ZAA2 *	0.25	0.44	0.57	3120	3.5	12	\$1,568
AMBZ 63 ZBA2 *	0.33	0.58	0.71	3310	3.5	13	\$1,551
AMBZ 63 ZCA2 *	0.50	0.87	1.09	3265	3.5	14	\$1,669
AMBZ 71 ZAA2	0.50	0.73	1.08	3300	3.5	18	\$1,645
AMBZ 71 ZBA2	0.75	1.10	1.58	3380	7.5	20	\$1,702
AMBZ 71 ZCA2	1.00	1.40	2.15	3320	7.5	22	\$1,824
AMBZ 80 ZAA2	1.00	1.50	2.09	3410	7.5	27	\$1,959
AMBZ 80 ZBA2	1.50	2.00	3.14	3400	15.0	32	\$2,044
AMBZ 80 ZCA2	2.00	2.50	4.19	3400	15.0	36	\$2,146
AMBZ 90S AA2 ☉	2.00	2.10	4.18	3410	15.0	41	\$2,511
AMBZ 90S BA2 ☉	2.50	2.50	5.21	3420	15.0	41	\$2,664
AMBZ 90L CA2 ☉	3.00	3.60	6.25	3420	15.0	48	\$2,769
AMBZ 90L DA2 ☉	4.00	4.50	8.27	3445	40.0	60	\$2,921
AMBZ 100L AA2	4.00	4.10	8.27	3445	40.0	63	\$3,240
AMBZ 100L BA2	5.50	5.60	11.59	3380	40.0	64	\$3,568
AMBZ 100L CA2	7.50	7.30	15.72	3400	40.0	78	\$3,804
AMBZ 112M AA2	5.50	5.90	11.42	3430	40.0	76	\$4,037
AMBZ 112M BA2	7.50	7.30	15.44	3460	40.0	83	\$4,422
AMBZ 112M CA2	10.00	10.00	20.59	3460	75.0	106	\$4,686
AMBZ 132S YA2	7.50	7.60	15.35	3480	75.0	124	\$6,101
AMBZ 132S ZA2	10.00	10.60	20.65	3450	75.0	137	\$6,738
AMBZ 132M ZA2	12.50	12.10	25.37	3510	75.0	148	\$7,523
AMBZ 132M RA2	15.00	15.20	30.93	3455	75.0	159	\$7,860
AMBZ 132M TA2	20.00	20.00	40.67	3504	150.0	183	\$8,392
AMBZ 160M VA2	15.00	16.50	30.27	3530	150.0	234	\$10,341
AMBZ 160M XA2	20.00	19.30	40.37	3530	150.0	271	\$11,307
AMBZ 160L XA2	25.00	25.70	50.31	3540	150.0	302	\$12,639
AMBZ 160L RA2	30.00	27.10	60.55	3530	150.0	302	\$14,720

6 POLE - 1200 RPM

Part Number	HP	Full Load Amps 575 V	Torque Nm	Speed Min ⁻¹	Max Brake Torque (Nm)	Weight (lbs)	Price (\$)
AMBZ 63 ZAA6 *	0.12	0.36	0.83	1030	3.5	15	\$1,733
AMBZ 71 ZAA6	0.25	0.62	1.70	1050	7.5	20	\$1,768
AMBZ 71 ZBA6	0.33	0.80	2.16	1090	7.5	21	\$1,817
AMBZ 80 ZAA6	0.50	0.91	3.27	1090	7.5	26	\$2,064
AMBZ 80 ZBA6	0.75	1.30	4.90	1090	15.0	32	\$2,186
AMBZ 90S AA6 ☉	1.00	1.70	6.25	1140	15.0	39	\$2,601
AMBZ 90L BA6 ☉	1.50	2.50	9.29	1150	40.0	52	\$2,829
AMBZ 100L AA6	2.00	3.60	12.39	1150	40.0	59	\$3,279
AMBZ 100L BA6	2.50	3.60	15.49	1150	40.0	69	\$3,526
AMBZ 112M AA6	3.00	4.10	18.59	1150	40.0	80	\$4,200
AMBZ 112M CA6	4.00	4.60	24.78	1150	75.0	117	\$4,869
AMBZ 132S ZA6	4.00	5.20	24.78	1150	75.0	124	\$6,201
AMBZ 132M YA6	5.50	7.00	34.07	1150	75.0	137	\$6,738
AMBZ 132M ZA6	7.50	9.40	46.46	1150	150.0	177	\$7,635
AMBZ 160M ZA6	10.00	11.60	61.95	1150	150.0	269	\$10,657
AMBZ 160L ZA6	15.00	15.60	92.93	1150	150.0	315	\$12,347

4 POLE - 1800 RPM

Part Number	HP	Full Load Amps 575 V	Torque Nm	Speed Min ⁻¹	Max Brake Torque (Nm)	Weight (lbs)	Price (\$)
AMBZ 63 ZAA4 *	0.16	0.36	0.70	1630	3.5	12	\$1,481
AMBZ 63 ZBA4 *	0.25	0.51	1.12	1590	3.5	13	\$1,541
AMBZ 63 ZCA4 *	0.33	0.58	1.44	1630	3.5	14	\$1,595
AMBZ 71 ZAA4	0.33	0.73	1.47	1600	3.5	17	\$1,634
AMBZ 71 ZBA4	0.50	0.91	2.16	1650	7.5	19	\$1,665
AMBZ 71 ZCA4	0.75	1.20	3.24	1650	7.5	22	\$1,716
AMBZ 80 ZAA4	0.75	1.20	3.18	1680	7.5	27	\$1,875
AMBZ 80 ZBA4	1.00	1.70	4.22	1690	15.0	32	\$1,956
AMBZ 80 ZCA4	1.50	2.00	6.44	1660	15.0	34	\$2,098
AMBZ 90S AA4 ☉	1.50	2.10	6.36	1680	15.0	39	\$2,364
AMBZ 90L BA4 ☉	2.00	2.70	8.60	1656	40.0	48	\$2,526
AMBZ 90L CA4 ☉	2.50	3.10	10.60	1680	40.0	51	\$2,761
AMBZ 90L DA4 ☉	3.00	3.90	12.72	1680	40.0	56	\$2,843
AMBZ 100L AA4	3.00	3.50	12.65	1690	40.0	64	\$3,021
AMBZ 100L BA4	4.00	5.00	16.76	1700	40.0	70	\$3,293
AMBZ 100L CA4	5.50	6.40	23.32	1680	75.0	85	\$3,622
AMBZ 112M AA4	5.50	5.70	22.78	1720	75.0	97	\$4,123
AMBZ 112M BA4	7.50	8.00	30.98	1725	75.0	97	\$4,339
AMBZ 132S AA4	7.50	7.80	31.16	1715	75.0	135	\$6,033
AMBZ 132M BA4	10.00	10.60	41.18	1730	75.0	154	\$6,733
AMBZ 132M CA4	12.50	10.90	50.89	1750	150.0	196	\$7,089
AMBZ 132M DA4	15.00	16.00	61.84	1728	150.0	196	\$8,360
AMBZ 160M AA4	15.00	15.30	61.07	1750	150.0	260	\$10,352
AMBZ 160L BA4	20.00	19.60	81.42	1750	150.0	300	\$11,406
AMBZ 160L CA4	25.00	26.60	101.78	1750	250.0	344	\$14,559
AMBZ 160L DA4	30.00	32.00	122.13	1750	250.0	340	\$15,141

8 POLE - 900 RPM

Part Number	HP	Full Load Amps 575 V	Torque Nm	Speed Min ⁻¹	Max Brake Torque (Nm)	Weight (lbs)	Price (\$)
AMBZ 71 ZAA8	0.16	0.65	1.50	760	7.5	20	\$2,107
AMBZ 80 ZAA8	0.33	0.87	2.90	810	7.5	26	\$2,259
AMBZ 90S AA8 ☉	0.50	1.30	4.40	810	15.0	38	\$2,761
AMBZ 90L BA8 ☉	0.75	2.00	6.60	810	15.0	46	\$2,916
AMBZ 100L AA8	1.00	1.90	8.69	820	40.0	59	\$3,424
AMBZ 100L BA8	1.50	2.90	12.88	830	40.0	70	\$3,794
AMBZ 112M AA8	2.00	3.50	17.17	830	40.0	100	\$4,466
AMBZ 132S ZA8	3.00	4.20	25.15	850	75.0	143	\$6,407
AMBZ 132M ZA8	4.00	5.70	33.14	860	150.0	163	\$7,022
AMBZ 160M YA8	5.50	6.50	45.56	860	150.0	229	\$9,952
AMBZ 160M ZA8	7.50	8.50	62.13	860	150.0	267	\$10,644
AMBZ 160L ZA8	10.00	11.00	83.82	850	150.0	313	\$11,826

* Non-removable feet - Side mount only (F2 standard/ F1 upon request)

☉ S/L dual set of holes on base (actual frame is 90L)

Frame sizes from 71 to 160 have removable feet.

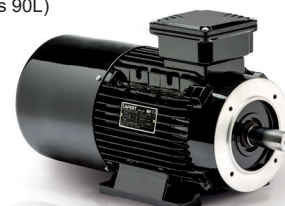

AMBZ brake motors do not come with a manual brake release lever (available upon request - for side exterior location of brake cover only).

AAF - High Brake Torque Full Size Brake Motors (230/460V)



3-Phase: 60Hz standard - AC 6 Lead-Coil Brake

1.15 Service Factor (SF) • 208 230V/460V or 333/575V (Inquire) • Brake Voltage Same as Motor Voltage

F2 Lead Box (F0 or F1 Available for Frame Sizes 71 and Above)

Adjustable Brake Torque • Manual Release Lever Included (rear end of motor) • TEFC • Squirrel Cage

Class F • IP54 • S3 60% Duty Cycle • IEC - CEI - UNEL MEC - CSA Approved

Dimensions: Page 28 & 29
Parts Breakdown: Page 15

2 POLE - 3600 RPM

Part Number	HP	Full Load Amps		Torque Nm	Speed Min ⁻¹	Max Brake Torque (Nm)	Weight (lbs)	Price (\$)
		460 V	575 V					
AAF 63 C2 *	0.25	0.55	0.45	0.57	3120	4.9	17	\$1,617
AAF 63 S2 *	0.35	0.75	0.6	0.75	3310	4.9	18	\$1,663
AAF 63 L2 *	0.50	1.1	0.9	1.09	3265	4.9	19	\$1,721
AAF 71 C2	0.50	0.95	0.75	1.08	3300	10.8	29	\$1,696
AAF 71 S2	0.75	1.4	1.1	1.58	3380	10.8	30	\$1,755
AAF 71 L2	1.00	1.85	1.5	2.15	3320	10.8	32	\$1,880
AAF 80 C2	1.00	1.8	1.4	2.09	3410	19.6	43	\$2,020
AAF 80 S2	1.50	2.3	1.9	3.14	3400	19.6	45	\$2,107
AAF 80 L2	2.00	2.8	2.3	4.19	3400	19.6	47	\$2,212
AAF 90S C2 ●	2.00	3.2	2.5	4.18	3410	34.3	57	\$2,643
AAF 90S L2 ●	2.50	3.9	3.1	5.21	3420	34.3	59	\$2,804
AAF 90L S2 ●	3.00	4.6	3.7	6.25	3420	34.3	64	\$2,915
AAF 100L C2	4.00	5.7	4.5	8.27	3445	54.0	73	\$3,411
AAF 100L S2	5.50	7.5	6	11.59	3380	54.0	80	\$3,756
AAF 112M C2	5.50	7.8	6.2	11.42	3430	88.3	112	\$4,249
AAF 112M S2	7.50	10.1	8.1	15.44	3460	88.3	119	\$4,655
AAF 132S L2	7.50	10.5	8.4	15.35	3480	166.8	149	\$6,422
AAF 132S C2	10.00	13.5	10.8	20.65	3450	166.8	162	\$7,093
AAF 132M S2	12.50	17.1	13.7	25.37	3510	166.8	177	\$7,919
AAF 132M A2	15.00	19.8	15.8	30.93	3455	166.8	184	\$8,274
AAF 160M C2	15.00	18.6	14.9	30.1	3550	264.9	275	\$10,885
AAF 160M S2	20.00	24	19.2	40.08	3555	264.9	298	\$11,902
AAF 160L L2	25.00	29.6	23.7	50.03	3560	264.9	326	\$13,304

4 POLE - 1800 RPM

Part Number	HP	Full Load Amps		Torque Nm	Speed Min ⁻¹	Max Brake Torque (Nm)	Weight (lbs)	Price (\$)
		460 V	575 V					
AAF 63 C4 *	0.18	0.45	0.35	0.79	1630	4.9	18	\$1,531
AAF 63 S4 *	0.25	0.60	0.50	1.12	1590	4.9	19	\$1,589
AAF 63 A4 *	0.33	0.80	0.65	1.44	1630	4.9	20	\$1,644
AAF 71 C4	0.35	0.85	0.65	1.56	1600	10.8	26	\$1,680
AAF 71 S4	0.50	1.10	0.90	2.16	1650	10.8	28	\$1,716
AAF 71 L4	0.70	1.60	1.25	2.97	1680	10.8	30	\$1,769
AAF 80 C4	0.75	1.50	1.20	3.18	1680	19.6	38	\$1,933
AAF 80 S4	1.00	2.00	1.60	4.22	1690	19.6	41	\$2,017
AAF 80 L4	1.30	2.60	2.10	5.58	1660	19.6	43	\$2,163
AAF 90S C4	1.50	2.50	2.00	6.36	1680	34.3	50	\$2,488
AAF 90L S4	2.00	3.30	2.70	8.60	1656	34.3	56	\$2,659
AAF 90L L4	2.50	3.90	3.10	10.60	1680	34.3	60	\$2,906
AAF 100L C4	3.00	5.00	4.00	12.65	1690	54.0	76	\$3,180
AAF 100L S4	4.00	6.30	5.10	16.76	1700	54.0	84	\$3,466
AAF 112M S4	5.50	7.60	6.30	22.78	1720	88.3	118	\$4,340
AAF 112M/4	7.50	9.70	7.80	30.80	1735	88.3	136	\$4,567
AAF 132S S4	7.50	10.50	8.40	30.98	1725	166.8	161	\$6,350
AAF 132M A4	10.00	14.20	11.40	41.54	1715	166.8	184	\$7,087
AAF 132M L4	12.50	16.60	13.30	50.89	1750	166.8	217	\$7,462
AAF 160M C4	15.00	19.10	15.30	60.72	1760	264.9	315	\$10,897
AAF 160L BA4	20.00	25.00	20.00	80.96	1760	264.9	344	\$12,006

6 POLE - 1200 RPM

Part Number	HP	Full Load Amps		Torque Nm	Speed Min ⁻¹	Max Brake Torque (Nm)	Weight (lbs)	Price (\$)
		460 V	575 V					
AAF 63 C6 *	0.12	0.55	0.45	0.87	980	4.9	19	\$2,274
AAF 71 C6	0.25	0.80	0.65	1.70	1050	10.8	30	\$1,823
AAF 71 S6	0.35	1.00	0.80	2.44	1020	10.8	31	\$1,873
AAF 80 C6	0.50	1.15	0.90	3.27	1090	19.6	37	\$2,128
AAF 80 S6	0.75	1.60	1.30	4.90	1090	19.6	40	\$2,254
AAF 90S C6 ●	1.00	2.20	1.80	6.25	1140	34.3	51	\$2,738
AAF 90L S6 ●	1.50	3.10	2.50	9.33	1145	34.3	58	\$2,978
AAF 100L C6	2.00	4.10	3.30	12.39	1150	54.0	69	\$3,452
AAF 100L S6	2.50	4.70	3.80	15.49	1150	54.0	76	\$3,712
AAF 112M C6	3.00	4.90	3.90	18.59	1150	88.3	109	\$4,423
AAF 112M A6	4.00	6.50	5.20	24.78	1150	88.3	128	\$5,125
AAF 132S C6	4.00	6.90	5.50	24.78	1150	88.3	150	\$6,527
AAF 132M S6	5.50	9.20	7.40	34.07	1150	88.3	163	\$7,093
AAF 132M A6	7.50	12.60	10.00	46.46	1150	88.3	193	\$8,037
AAF 160M C6	10.00	13.90	11.10	60.89	1170	264.9	309	\$11,218
AAF 160L S6	15.00	19.80	15.80	91.73	1165	264.9	341	\$12,997

8 POLE - 900 RPM

Part Number	HP	Full Load Amps		Torque Nm	Speed Min ⁻¹	Max Brake Torque (Nm)	Weight (lbs)	Price (\$)
		460 V	575 V					
AAF 71 C8	0.20	0.60	0.50	1.87	760	10.8	28	\$2,281
AAF 80 C8	0.35	1.00	0.80	3.08	810	19.6	36	\$2,734
AAF 90S C8 ●	0.50	1.60	1.25	4.40	810	34.3	56	\$3,109
AAF 90L S8 ●	0.75	2.30	1.85	6.60	810	34.3	62	\$3,284
AAF 100L C8	1.00	2.40	1.95	8.69	820	54.0	69	\$3,856
AAF 100L S8	1.50	3.60	2.90	12.88	830	54.0	80	\$4,274
AAF 112M C8	2.00	4.30	3.40	17.17	830	88.3	119	\$5,030
AAF 132S C8	3.00	5.90	4.80	25.15	850	88.3	163	\$7,216
AAF 132M S8	4.00	7.50	6.00	33.14	860	88.3	182	\$7,909
AAF 160M C8	5.50	8.60	6.90	45.30	865	264.9	266	\$11,209
AAF 160M S8	7.50	12.50	10.00	61.42	870	264.9	290	\$11,988
AAF 160L L8	10.00	15.40	12.30	86.88	820	264.9	306	\$13,319

* Non-removable feet - Side mount only (F2 standard/ F1 upon request)

Frame sizes from 71 to 160 have removable feet.



Exploded View: Page 15

● S/L dual set of holes on base (actual frame is 90L)

NOTE:

- Contact us for replacement brake components.
- Special brake voltages available. Please inquire.

AAFB - 2-Speed High Brake Torque Full Size Brake Motors



3-Phase: 60Hz standard - AC 6 Lead - Coil Brake

1.0 Service Factor (SF) • 230V, 460V or 575V • Adjustable Brake Torque • Manual Release Included

F2 Lead Box (F0 or F1 Available for Frame Sizes 71 and Above)

Squirrel Cage • TEFC • Class F • S6 60% Duty Cycle • IP54 • IEC • CEI • UNEL MEC • CSA Approved

Dimensions: Pages 28 & 29

2/4 POLE - 3600/1800 RPM - 1 WINDING

Part Number	HP	Weight (lbs)	Full Load Amps		Price (\$)
			460 V	575 V	
AAFB 63 S2/4 *	0.40/0.27	19	0.80/0.62	0.64/0.50	\$2,163
AAFB 71 C2/4	0.60/0.40	33	1.36/0.96	1.09/0.77	\$2,401
AAFB 80 C2/4	0.80/0.60	43	1.44/1.12	1.15/0.90	\$2,673
AAFB 80 S2/4	1.00/0.75	50	1.76/1.44	1.41/1.15	\$2,765
AAFB 80 L2/4	1.50/1.10	57	2.48/1.92	1.98/1.54	\$2,856
AAFB 90L C2/4	2.10/1.60	63	3.12/2.72	2.50/2.18	\$3,464
AAFB 90L S2/4	2.60/1.90	66	3.60/2.88	2.88/2.30	\$3,628
AAFB 100L C2/4	3.40/2.50	76	4.72/3.60	3.78/2.88	\$4,311
AAFB 100L L2/4	4.00/3.00	77	6.16/4.64	4.93/3.71	\$4,501
AAFB 100L S2/4	4.50/3.50	80	6.56/5.28	5.25/4.22	\$4,913
AAFB 112M C2/4	6.00/4.50	121	8.16/5.76	6.53/4.61	\$6,339
AAFB 132S S2/4	7.50/6.00	163	9.60/9.60	7.68/7.68	\$8,728
AAFB 132M L2/4	11.00/9.00	181	13.60/12.80	10.88/10.24	\$9,793
AAFB 160M C2/4	15.00/12.00	317	18.00/17.60	14.4/14.08	\$14,375
AAFB 160L S2/4	20.00/17.00	333	24.80/22.80	19.84/18.24	\$15,909

4/8 POLE - 1800/900 RPM - 1 WINDING

Part Number	HP	Weight (lbs)	Full Load Amps		Price (\$)
			460 V	575 V	
AAFB 71 C4/8	0.35/0.18	31	0.56/0.64	0.45/0.51	\$2,703
AAFB 80 C4/8	0.50/0.25	45	0.83/0.63	0.66/0.50	\$2,993
AAFB 80 S4/8	0.70/0.35	45	1.12/1.04	0.90/0.83	\$3,065
AAFB 90S C4/8	1.00/0.50	58	1.68/1.44	1.34/1.15	\$3,645
AAFB 90L S4/8	1.30/0.70	63	1.92/1.76	1.54/1.41	\$3,928
AAFB 100L C4/8	1.90/0.90	75	2.72/2.80	2.18/2.24	\$4,469
AAFB 112M C4/8	2.40/1.40	111	3.36/3.20	2.69/2.56	\$5,511
AAFB 112M S4/8	3.00/1.80	117	4.16/3.68	3.33/2.94	\$6,084
AAFB 132S C4/8	5.00/2.80	159	7.68/5.76	6.14/4.61	\$8,815
AAFB 132M S4/8	6.50/3.50	195	9.36/6.72	7.49/5.38	\$9,603
AAFB 160M C4/8	8.50/5.50	256	9.60/9.60	7.68/7.68	\$13,626
AAFB 160L S4/8	10.00/6.50	278	13.20/11.36	10.56/9.09	\$15,089
AAFB 160L L4/8	14.00/8.00	299	16.80/14.40	13.44/11.52	\$16,512

4/6 POLE - 1800/1200 RPM - 2 WINDING

Part Number	HP	Weight (lbs)	Full Load Amps		Price (\$)
			460 V	575 V	
AAFB 71 C4/6	0.35/0.25	32	0.64/0.56	0.51/0.45	\$2,765
AAFB 80 A4/6	0.50/0.35	42	0.84/0.80	0.67/0.64	\$3,149
AAFB 80 C4/6	0.75/0.50	46	1.28/1.12	1.02/0.90	\$3,266
AAFB 90L C4/6	1.20/0.80	64	2.00/2.00	1.60/1.60	\$3,898
AAFB 100L L4/6	1.50/1.00	83	2.88/2.08	2.30/1.66	\$4,513
AAFB 100L C4/6	2.00/1.20	102	3.12/2.32	2.50/1.86	\$4,781
AAFB 112M C4/6	2.50/1.80	115	3.92/3.36	3.14/2.69	\$5,768
AAFB 112M S4/6	3.50/2.50	124	4.96/4.24	3.97/3.39	\$6,593
AAFB 132M C4/6	5.50/3.50	187	7.60/6.00	6.08/4.80	\$9,125
AAFB 160M C4/6	7.50/5.00	265	10.80/8.00	8.64/6.40	\$13,945
AAFB 160M S4/6	10.00/6.50	289	13.20/9.60	10.56/7.68	\$14,707
AAFB 160L L4/6	13.00/9.00	311	20.00/13.60	16.00/10.88	\$16,068

6/8 POLE - 1200/900 RPM - 2 WINDING

Part Number	HP	Weight (lbs)	Full Load Amps		Price (\$)
			460 V	575 V	
AAFB 71 C6/8	0.30/0.15	31	0.70/0.46	0.56/0.37	\$2,822
AAFB 80 C6/8	0.50/0.25	45	1.09/0.72	0.87/0.58	\$3,486
AAFB 90L C6/8	0.75/0.40	64	1.68/1.48	1.34/1.18	\$4,501
AAFB 100L C6/8	1.00/0.60	80	1.84/1.68	1.47/1.34	\$5,072
AAFB 112M C6/8	1.30/0.90	112	2.48/1.84	1.98/1.47	\$5,960
AAFB 112M S6/8	2.00/1.00	121	3.60/1.84	2.88/1.47	\$6,466
AAFB 132M A6/8	3.00/1.70	154	5.52/4.16	4.41/3.33	\$9,351
AAFB 132M C6/8	4.00/2.30	185	6.64/4.72	5.31/3.77	\$10,997
AAFB 160M C6/8	6.50/3.50	285	9.20/6.32	7.36/5.06	\$15,848
AAFB 160L S6/8	8.00/4.50	307	12.16/9.60	9.73/7.68	\$17,811

* Non-removable feet - Side mount only (F2 standard/ F1 upon request)

⊙ S/L dual set of holes on base (actual frame is 90L)

Frame sizes from 71 to 160 have removable feet.

2/8 POLE - 3600/900 RPM - 2 WINDING

Part Number	HP	Weight (lbs)	Full Load Amps		Price (\$)
			460 V	575 V	
AAFB 80 C2/8	0.50/0.15	40	1.04/0.56	0.83/0.45	\$3,516
AAFB 80 S2/8	0.75/0.15	51	1.12/0.67	0.90/0.54	\$3,666
AAFB 90L C2/8	1.00/0.25	58	2.00/0.92	1.60/0.74	\$4,535
AAFB 90L S2/8	1.50/0.40	73	2.64/1.20	2.11/0.96	\$4,535
AAFB 100L S2/8	2.00/0.50	76	2.80/1.60	2.24/1.28	\$5,072
AAFB 100L L2/8	2.50/0.60	77	3.44/1.76	2.75/1.41	\$5,643
AAFB 112M C2/8	2.50/1.45	119	4.00/2.96	3.20/2.37	\$6,593
AAFB 112M L2/8	3.00/0.75	120	4.40/1.60	3.52/1.28	\$6,909
AAFB 132S C2/8	4.00/1.00	158	6.90/4.00	5.52/3.20	\$9,351
AAFB 132M S2/8	6.00/1.50	184	7.60/5.60	6.08/4.48	\$10,980



NOTE:

- Contact us for replacement brake components.
- Special brake voltages available. Please inquire.

3-Phase Brake Motors

In the event of a power failure, the motor, and the machinery it is driving, will stop immediately, braking is SAFE, POWERFUL and FAST. The “dead” time created by the inertia of rotating parts is reduced to a minimum. Braking power is independent of the direction of rotation. The instant braking action of these motors is particularly suited to situations where accurate positioning and ability to repeat is essential.

The standard configuration includes two separate terminal blocks supplying electrical current and controls. One supplies the brake, the other supplies the motor. The materials used in the construction of all friction surfaces are designed to withstand frequent stops per hour. Special care has been taken to ensure proper heat dissipation.

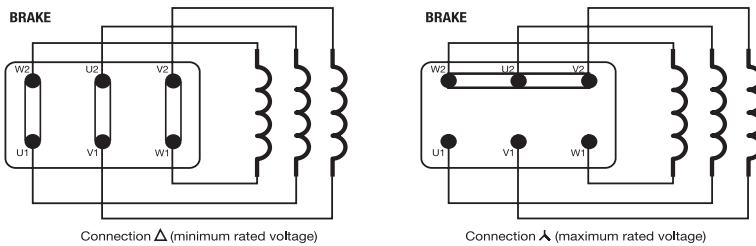

All brake coils are designed with standard three phase voltage (AC) 230/460v or 333/575v - regardless of what voltage the motor winding might be. Special brake coil voltage can be supplied upon request.

ELECTROMAGNET REPLACEMENT:

Unscrew the manual releasing lever (41) if the brake has one. Remove the brake cover (39). Release the six wires connecting the brake to the terminal board (20). Unscrew the nuts (35/5) and remove the electromagnet (38) from the pilot pin (35/1). Place the new electromagnet on the pilot pin. Replace and tighten the nuts (35/5). Adjust the nuts (35/4) to equalize the value of the air gap to factory specifications (between 0.5 - 0.8mm).

Insert the feed cables through the hole from the braking section. Reconnect all previous connections.

DISK BRAKE REPLACEMENT:

Unscrew the manual release lever (41) if the brake has one. Unscrew the nuts (35/5) and remove the electromagnet (38). Unscrew nuts (35/4) and self locking nut (35/3) and extract the spring (35/2) and countermagnet (37) and extract the disk brake (36). With clean hands, install the new disk brake. Take precautions that the O-ring (34) is properly installed on the brake support flange (32). Make sure the disk brake has a minimum clearance of 0.3mm from the friction path. Replace the countermagnet (37) and spring (35/2) and replace nuts (35/3) and (35/4). Replace the electromagnet and nuts (35/5). Be sure to maintain an air gap of between 0.5 and 0.8mm to regulate the air gap and braking torque.

AIR GAP REGULATION:

The air gap i.e., the distance between the electromagnet (38) and the countermagnet (37) must be carefully set between 0.5 and 0.8mm. If this

distance is not carefully maintained because of worn disk brakes or incorrect adjustment procedures, vibration of the countermagnet or even the burning of the electromagnet could result.

It is recommended that you check the air gap periodically (every 1,000,000 insertions) since the gap tends to increase with usage of the disk brake. Regular inspection will ensure trouble-free operation and reduced down-time. To regulate the air gap, adjust nuts (35/4) and (35/5). Be sure to maintain an even air gap of 0.5 and 0.8mm between the two mating surfaces.

BRAKE TORQUE REGULATION:

The braking torque can be manually adjusted over a wide range simply by varying the pressure of the springs acting on the moving armature of the electromagnet. Braking action is achieved by moving the mobile armature against a brake disc which is rigidly keyed to the motor shaft. Axial movement is blocked by the motor flange

The braking torque is proportional to the pressure exerted by the springs (35/2) and may be varied by adjusting the self-locking nuts (35/3). The pressure of the springs must be as uniform as possible. When applying the brake, the electromagnet (38) should attract the countermagnet (37) and hold it without creating vibration in order to achieve maximum braking torque. To reduce the braking torque, loosen the self-locking nuts (35/3) further until the desired amount of torque has been achieved.

Parts Breakdown for AAF/AAFB Brake Motors

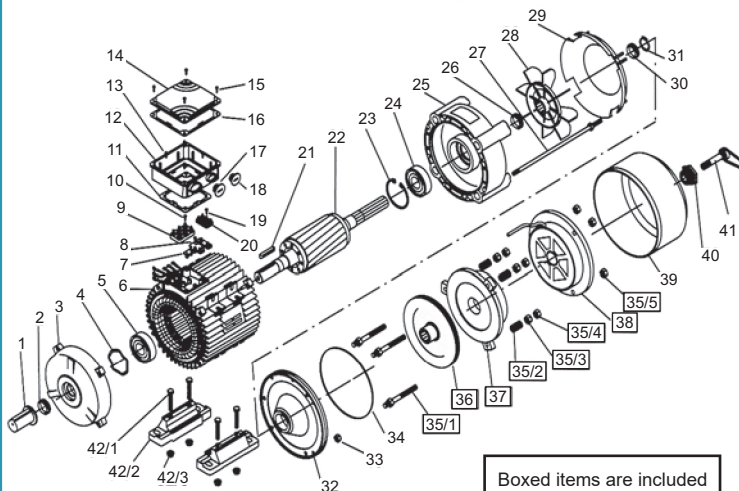

PART DESCRIPTION:

- | | |
|---|---|
| 1 Shaft protection | 26 Dust seal |
| 2 Dust seal drive end | 27 Tie rod |
| 3 End shield drive end | 28 Fan |
| 4 Preload washer | 29 Fan cover |
| 5 Bearing drive end | 30 Dust seal (for IP55 only) |
| 6 Slater frame | 31 Circlip (for fan locking) |
| 7 Terminal board support (for sizes 63 ... 112) | 32 Brake support flange |
| 8 Fixing screw terminal board support (for sizes 63... 112] | 33 Tie rod fixing nut |
| 9 Motor terminal board | 34 O-ring (for IP55 only) |
| 10 Fixing screw motor terminal board | 35 Brake adjusting fixing kit: |
| 11 Gasket terminal box | [35/1] guiding column |
| 12 Terminal box | [35/2] braking spring |
| 13 Fixing screw terminal box | [35/3] self-locking nut |
| 14 Gasket terminal box lid | [35/4] electromagnet locking nut |
| 15 Terminal box lid | [35/5] electromagnet locking nut |
| 16 Fixing screw terminal box lid | 36 Brake disk |
| 17 Blank gland plug | 37 Countermagnet (Brake anchor) |
| 18 Blank gland plug | 38 Electromagnet |
| 19 Fixing screw brake terminal board (for sizes 63... 112) | 39 Brake cover |
| 20 Brake terminal board (for sizes 63... 112) | 40 Nipple |
| 21 Motor key | 41 Manual brake release lever |
| 22 Rotor complete | 42 Foot kit (1 foot) for sizes 71 - 160 |
| 23 Circlip | 42/1 fixing screw |
| 24 Bearing non drive end | 42/2 foot |
| 25 End shield non-drive end | 42/3 fixing nut |

MS - Low Brake Torque Compact Brake Motors



3-Phase: 60Hz Standard - DC Brake Coil

1.15 Service Factor (SF) • 208 230/460V or 333/575V • F2 Lead Box (F0 or F1 Available for Frame Sizes 71 and Above)

Brake Voltage Standard 230V-AC into Rectifier with 460V Motor, or 333V-AC into Rectifier with 575V motor

TEFC • Squirrel Cage • Class F • IP54 • S6 70% Duty Cycle • IEC - CEI - UNEL MEC - CSA approved

Dimensions: Pages 28 & 29
Connection Diagram: Page 58

2 POLE - 3600 RPM

Part Number	HP	Full Load Amps		Rated Torque Nm	Speed Min ⁻¹	Max Brake Torque (Nm)	Weight (lbs)	Price (\$)
		460 V	575 V					
MS 63 C2 *	0.25	0.55	0.45	0.57	3120	3	11	\$1,405
MS 63 S2 *	0.35	0.75	0.60	0.75	3310	3	12	\$1,441
MS 63 L2 *	0.50	1.10	0.90	1.09	3265	3	12	\$1,460
MS 71 C2	0.50	0.95	0.75	1.08	3300	4	15	\$1,534
MS 71 S2	0.75	1.40	1.10	1.58	3380	4	16	\$1,616
MS 71 L2	1.00	1.85	1.50	2.15	3320	4	18	\$1,689
MS 80 C2	1.00	1.80	1.40	2.09	3410	7	23	\$1,790
MS 80 S2	1.50	2.30	1.90	3.14	3400	7	26	\$1,927
MS 80 L2	2.00	2.80	2.30	4.19	3400	7	29	\$2,042
MS 90S C2	2.00	3.20	2.50	4.18	3410	7	32	\$2,276
MS 90S L2	2.50	3.90	3.10	5.21	3420	7	36	\$2,527
MS 90L S2	3.00	4.60	3.70	6.25	3420	7	40	\$2,651
MS 90L DA2	4.00	5.80	4.60	8.19	3480	7	50	\$2,836
MS 100L C2	4.00	5.70	4.50	8.27	3445	13	51	\$3,133
MS 100L S2	5.50	7.50	6.00	11.59	3380	13	58	\$3,486
MS 100L CA2	7.50	9.20	7.40	15.31	3490	13	68	\$3,626
MS 112M C2	5.50	7.80	6.20	11.42	3430	13	67	\$3,785
MS 112M S2	7.50	10.10	8.10	15.44	3460	13	81	\$4,181
MS 112M CA2	10.00	12.30	9.80	20.24	3520	13	86	\$4,468
MS 132S L2	7.50	10.50	8.40	15.35	3480	30	95	\$4,850
MS 132S C2	10.00	13.50	10.80	20.65	3450	30	108	\$6,098
MS 132M S2	12.50	17.10	13.70	25.37	3510	30	127	\$6,645
MS 132M A2	15.00	19.80	15.80	30.93	3455	30	129	\$7,469
MS 160M VA2	15.00	18.60	14.90	30.10	3550	30	193	\$8,024
MS 160M XA2	20.00	24.00	19.20	40.08	3555	30	232	\$9,596
MS 160L XA2	25.00	29.60	23.70	50.03	3560	30	263	\$11,433
MS 160L RA2	30.00	33.50	26.80	60.21	3550	30	263	\$12,353

4 POLE - 1800 RPM

Part Number	HP	Full Load Amps		Rated Torque Nm	Speed Min ⁻¹	Max Brake Torque (Nm)	Weight (lbs)	Price (\$)
		460 V	575 V					
MS 63 C4 *	0.18	0.45	0.35	0.79	1630	3	10	\$1,364
MS 63 S4 *	0.25	0.60	0.50	1.12	1590	3	12	\$1,410
MS 63 A4 *	0.33	0.80	0.65	1.44	1630	3	12	\$1,451
MS 71 C4	0.35	0.85	0.65	1.56	1600	4	15	\$1,524
MS 71 S4	0.50	1.10	0.90	2.16	1650	4	16	\$1,580
MS 71 L4	0.70	1.60	1.25	2.97	1680	4	19	\$1,667
MS 71 ZCA4	0.75	1.50	1.20	3.20	1670	4	21	\$1,676
MS 80 C4	0.75	1.50	1.20	3.18	1680	7	23	\$1,767
MS 80 S4	1.00	2.00	1.60	4.22	1690	7	25	\$1,833
MS 80 L4	1.30	2.60	2.10	5.58	1660	7	28	\$1,993
MS 90S C4	1.50	2.50	2.00	6.36	1680	7	32	\$2,138
MS 90L S4	2.00	3.30	2.70	8.60	1656	7	36	\$2,334
MS 90L L4	2.50	3.90	3.10	10.60	1680	7	41	\$2,596
MS 90L DA4	3.00	5.00	4.00	12.50	1710	7	46	\$2,725
MS 100L C4	3.00	5.00	4.00	12.65	1690	13	50	\$2,863
MS 100L S4	4.00	6.30	5.10	16.76	1700	13	56	\$3,164
MS 100L CA4	5.50	8.20	6.60	22.78	1720	13	66	\$3,497
MS 112M S4	5.50	7.60	6.30	22.78	1720	13	74	\$3,833
MS 112M BA4	7.50	9.70	7.80	30.80	1735	13	86	\$4,409
MS 132S A4	7.50	10.50	8.40	30.98	1725	30	106	\$5,314
MS 132M S4	10.00	14.20	11.40	41.54	1715	30	126	\$6,242
MS 132M RA4	12.50	16.60	13.30	50.89	1750	30	164	\$7,040
MS 132M TA4	15.00	19.90	15.90	61.42	1740	30	164	\$7,662
MS 160M XA4	15.00	19.10	15.30	60.72	1760	30	218	\$7,855
MS 160L XA4	20.00	25.00	20.00	80.96	1760	30	260	\$10,130
MS 160L ZA4	25.00	31.30	25.00	101.20	1760	30	280	\$11,797
MS 160L RA4	30.00	37.30	29.80	122.13	1750	30	283	\$12,540

6 POLE - 1200 RPM

Part Number	HP	Full Load Amps		Rated Torque Nm	Speed Min ⁻¹	Max Brake Torque (Nm)	Weight (lbs)	Price (\$)
		460 V	575 V					
MS 63 C6 *	0.12	0.55	0.45	0.87	980	3	12	\$1,964
MS 71 C6	0.25	0.80	0.65	1.70	1050	4	16	\$1,716
MS 71 S6	0.35	1.00	0.80	2.44	1020	4	17	\$1,776
MS 80 C6	0.50	1.15	0.90	3.27	1090	7	23	\$1,941
MS 80 S6	0.75	1.60	1.30	4.90	1090	7	25	\$2,081
MS 90S C6	1.00	2.20	1.80	6.25	1140	7	30	\$2,338
MS 90L S6	1.50	3.10	2.50	9.33	1145	7	38	\$2,603
MS 100L C6	2.00	4.10	3.30	12.39	1150	13	46	\$3,036
MS 100L S6	2.50	4.70	3.80	15.49	1150	13	56	\$3,356
MS 112M C6	3.00	4.90	3.90	18.59	1150	13	73	\$4,043
MS 112M A6	4.00	6.50	5.20	24.78	1150	13	87	\$4,736
MS 132S C6	4.00	6.90	5.50	24.78	1150	30	95	\$5,630
MS 132M S6	5.50	9.20	7.40	34.07	1150	30	108	\$6,067
MS 132M A6	7.50	12.60	10.00	46.46	1150	30	136	\$7,038
MS 160M ZA6	10.00	13.90	11.10	60.89	1170	30	230	\$8,202
MS 160L ZA6	15.00	19.80	15.80	91.73	1165	30	275	\$11,125

8 POLE - 900 RPM

Part Number	HP	Full Load Amps		Rated Torque Nm	Speed Min ⁻¹	Max Brake Torque (Nm)	Weight (lbs)	Price (\$)
		460 V	575 V					
MS 71 C8	0.20	0.60	0.50	1.87	760	4	16	\$1,911
MS 80 C8	0.35	1.00	0.80	3.08	810	7	23	\$2,323
MS 90S C8	0.50	1.60	1.25	4.40	810	7	30	\$2,649
MS 90L S8	0.75	2.30	1.85	6.60	810	7	38	\$2,867
MS 100L C8	1.00	2.40	1.95	8.69	820	13	46	\$3,317
MS 100L S8	1.50	3.60	2.90	12.88	830	13	57	\$3,768
MS 112M C8	2.00	4.30	3.40	17.17	830	13	88	\$4,397
MS 132S C8	3.00	5.90	4.80	25.15	850	30	114	\$5,883
MS 132M S8	4.00	7.50	6.00	33.14	860	30	134	\$6,721
MS 160M YA8	5.50	8.60	6.90	45.30	865	30	190	\$7,344
MS 160M ZA8	7.50	12.50	10.00	61.42	870	30	226	\$8,816
MS 160L ZA8	10.00	15.40	12.30	86.88	820	30	273	\$10,933

* Non-removable feet - side mount only (F2 standard/ F1 upon request)
 S/L dual set of holes on base (actual frame is 90L)

Frame sizes from 71 to 160 have removable feet.

MS Range Braking Torque (Kgm)
 63/71 frame = 0.40
 80/90 frame = 0.70
 100/112 frame = 1.4
 132/160 frame = 3.1
 To convert KGM to fl/lbs, multiply by 7.231

Different brake (DC) coil voltages are available upon request:
ACTUAL 148V-DC - for 575V units (SS2 half wave)
 206V-DC - for 460V units (STD1 full wave)
OPTIONAL 24V-DC
 103V-DC - STD1

Available options:

- Single phase brake motors
- Manual release lever
- 2-Speed version
- Rapid speed special diode rectifier bridge for quicker stops
- Special coil voltages

MS Brake Motor - Parts Breakdown

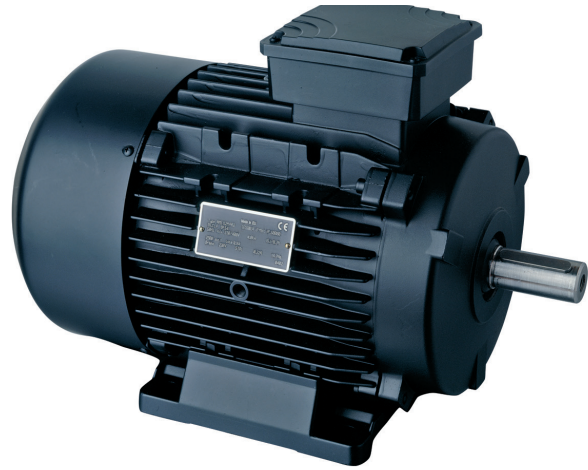
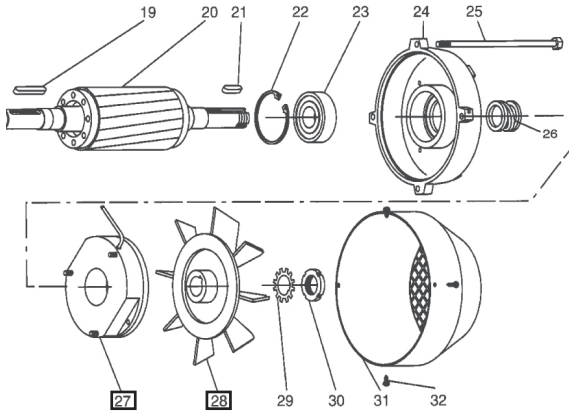

PART DESCRIPTION:

- 19 Motor key
- 20 Rotor complete
- 21 Brake key
- 22 Circlip
- 23 Bearing non-drive end
- 24 Endshield non-drive end
- 25 Tie rod
- 26 Main contrast spring
- 27 Pre-assembled part of the brake (electromagnet, brake anchor with friction surface, braking springs, fixing screws)
- 28 Brake fan
- 29 Lock washer
- 30 Air gap adjustment ring nut
- 31 Fan cover
- 32 Fixing screw fan cover

BOXED ITEMS ARE INCLUDED IN A BRAKE ASSEMBLY KIT

Single Phase Motor - Capacitor Start & Run Connection Diagrams

Dual Voltage

Single Voltage

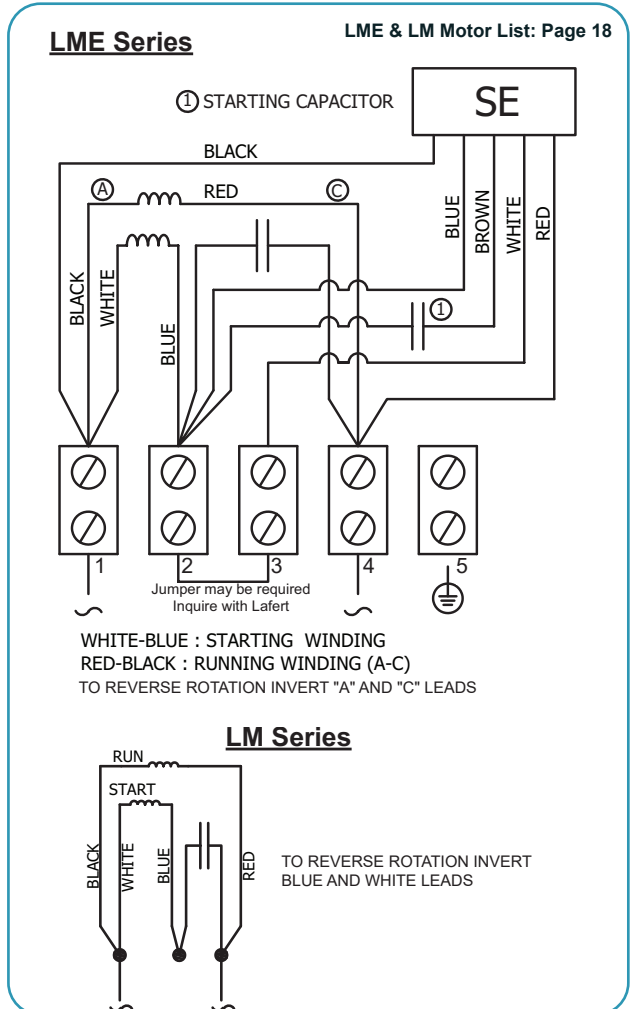
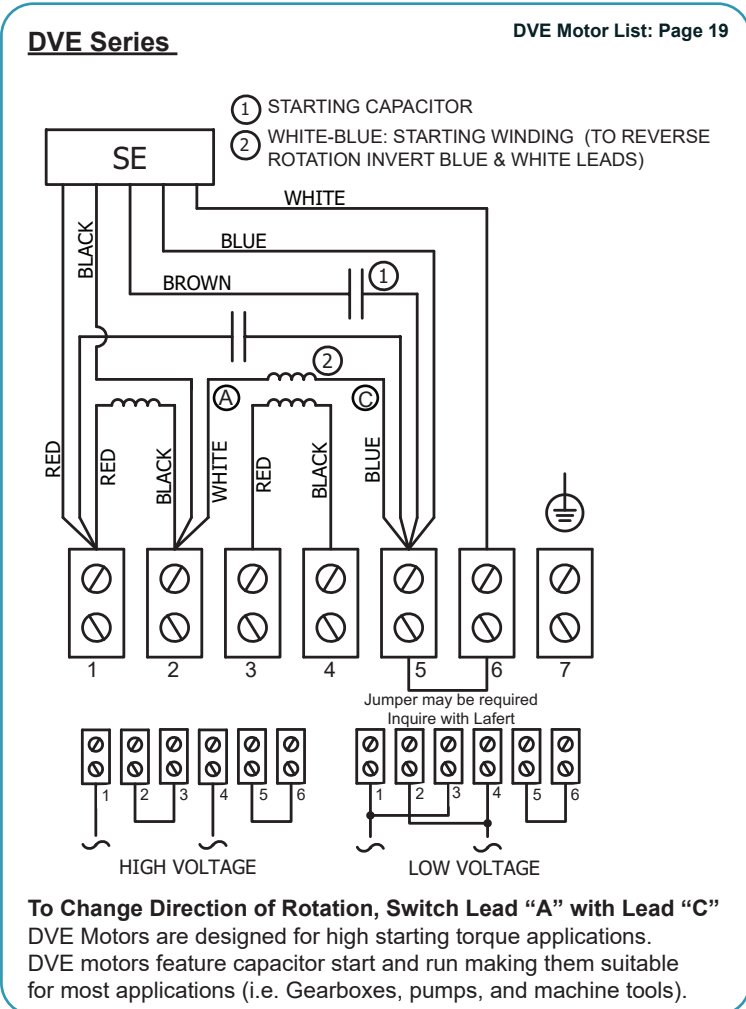

LM / LME - Single Phase Motors (Single Voltage)



1-Phase - 60 Hz Standard

1.0 Service Factor (SF) • 115V or 230V • TEFC • Squirrel Cage • Class F • IP54 • IEC - CEI - UNEL MEC - CSA approved
F2 Lead Box (F0 or F1 Available for 71 Size Frame and Above)

Dimensions: Pages 25 & 29
Connection Diagram: Page 17

Available options: Self braking • Thermal protection • Custom shafts and flanges available

2 POLE - 3600 RPM

Part Number	HP	Weight (lbs)	Rated Torque Nm	Speed Min ⁻¹	115V				230V				LM Price (\$)	LME Price (\$)
					Full Load Amps	Run Cap (µf)	(LME) Start Cap (µf)	(LME) Current Relay	Full Load Amps	Run Cap (µf)	(LME) Start Cap (µf)	(LME) Current Relay		
LM 56 C2 *	0.15	8	0.32	3300	2.5	16.0	-	-	1.2	4.0	-	-	\$600	-
LM(E) 63 C2 *	0.15	10	0.32	3300	2.4	16.0	53+20%	SE02	1.2	4.0	16+20%	SE02	\$608	\$803
LM(E) 63 S2 *	0.25	11	0.50	3450	3.2	25.0	53+20%	SE01	1.4	6.3	12.5+20%	SE01	\$616	\$820
LM(E) 63 L2 *	0.33	12	0.66	3465	3.7	25.0	53+20%	SE01	1.8	8.0	20+20%	SE01	\$670	\$849
LM(E) 71 C2	0.50	16	1.00	3340	8.7	20.0	36+20%	SE02	3.8	12.5	30+20%	SE01	\$741	\$973
LM(E) 71 S2	0.75	19	1.50	3450	7.9	16.0	53+20%	SE02	3.8	16.0	30+20%	SE02	\$816	\$1,047
LM(E) 80 C2	1.00	25	2.10	3450	12.0	60.0	124+20%	SE01	5.8	16.0	30+20%	SE02	\$949	\$1,201
LM(E) 80 S2	1.50	25	3.10	3345	13.6	50.0	161+20%	SE01	6.7	25.0	124+20%	SE02	\$1,003	\$1,300
LM(E) 80/2	2.00	32	3.10	3450	16.8	60.0	189+20%	SE02	8.1	50.0	161+20%	SE02	\$1,318	\$1,701
LM(E) 90S C2 ☉	1.50	36	3.10	3440	16.0	60.0	189+20%	SE02	7.5	50.0	124+20%	SE03	\$1,211	\$1,509
LM(E) 90L S2 ☉	2.00	38	4.30	3350	22.0	70.0	189+20%	SE02	11.0	36.0	108+20%	SE02	\$1,324	\$1,624
LM(E) 90L L2 ☉	2.50	41	5.00	3450	23.0	50.0	161+20%	SE02	11.5	40.0	124+20%	SE02	\$1,454	\$1,749
LM(E) 100L C2	3.00	54	6.20	3405	25.8	80.0	187+21.5%	SE01	13.5	50.0	161+20%	SE03	\$1,669	\$1,995
LME 100L S2	5.00	58	10.50	-	-	-	-	-	21.0	50.0	161+20%	SE02	-	\$2,829

4 POLE - 1800 RPM

Part Number	HP	Weight (lbs)	Rated Torque Nm	Speed Min ⁻¹	115V				230V				LM Price (\$)	LME Price (\$)
					Full Load Amps	Run Cap (µf)	(LME) Start Cap (µf)	(LME) Current Relay	Full Load Amps	Run Cap (µf)	(LME) Start Cap (µf)	(LME) Current Relay		
LM 56 S4 *	0.12	8	0.52	1650	2.0	25.0	-	-	0.9	6.3	-	-	\$600	-
LM(E) 63 A4 *	0.15	10	0.60	1700	2.4	16.0	30+20%	SE02	1.2	8.0	16+20%	SE01	\$608	\$803
LM(E) 63 C4 *	0.25	11	1.00	1680	3.1	25.0	30+20%	SE01	1.6	8.0	16+20%	SE01	\$641	\$839
LM(E) 71 C4	0.33	16	1.35	1620	4.6	12.5	30+20%	SE02	2.2	10.0	16+20%	SE02	\$717	\$949
LM(E) 71 S4	0.40	17	1.60	1730	5.9	16.0	20+20%	SE02	2.8	12.5	30+20%	SE01	\$750	\$983
LM(E) 71 L4	0.50	19	2.10	1700	6.5	25.0	30+20%	SE01	3.2	16.0	53+20%	SE02	\$835	\$1,066
LM(E) 80 C4	0.50	22	2.05	1710	5.5	50.0	124+20%	SE01	2.8	12.5	30+20%	SE02	\$892	\$1,146
LM(E) 80 S4	0.75	25	3.10	1710	9.1	50.0	124+20%	SE01	4.6	12.5	53+20%	SE01	\$929	\$1,180
LM(E) 80 L4	1.00	28	4.20	1700	10.6	50.0	124+20%	SE01	4.9	20.0	88+20%	SE01	\$971	\$1,222
LM(E) 90L C4 ☉	1.50	34	6.25	1700	15.0	50.0	124+20%	SE02	8.3	25.0	108+20%	SE01	\$1,241	\$1,537
LM(E) 90L S4 ☉	2.00	39	8.60	1630	22.0	60.0	108+20%	SE02	10.0	31.5	124+20%	SE01	\$1,362	\$1,656
LM(E) 100L C4	2.50	50	10.10	1710	25.0	50.0	161+20%	SE02	12.0	50.0	124+20%	SE01	\$1,666	\$1,990
LM(E) 100L S4	3.00	53	12.40	1690	27.0	60.0+70.0	324+20%	SE02	13.3	50.0	189+20%	SE02	\$1,809	\$2,131
LME 112M /4	5.00	76	21.00	-	-	-	-	-	22.0	60.0	2x108+20%	SE02	-	\$2,827

6 POLE - 1200 RPM

Part Number	HP	Weight (lbs)	Rated Torque Nm	Speed Min ⁻¹	115V				230V				LM Price (\$)	LME Price (\$)
					Full Load Amps	Run Cap (µf)	(LME) Start Cap (µf)	(LME) Current Relay	Full Load Amps	Run Cap (µf)	(LME) Start Cap (µf)	(LME) Current Relay		
LM(E) 71 C6	0.20	18	1.50	1100	3.8	25.0	53+20%	SE02	1.8	6.3	12.5+20%	SE01	\$1,044	\$1,366
LM(E) 80 C6	0.35	19	2.10	1150	4.6	40.0	108+20%	SE02	2.2	10.0	30+20%	SE02	\$1,205	\$1,483
LM(E) 80 S6	0.50	22	3.10	1150	5.9	50.0	124+20%	SE02	2.7	12.5	40+20%	SE01	\$1,341	\$1,622
LM(E) 90L C6 ☉	0.75	36	4.80	1100	10.0	90.0	124+20%	SE02	4.7	31.5	64+20%	SE02	\$1,732	\$2,174
LM(E) 90L S6 ☉	1.00	40	6.50	1110	10.2	50.0	88+20%	SE02	5.0	31.5	64+20%	SE02	\$1,857	\$2,308
LM(E) 100L C6	1.50	42	9.30	1130	16.6	170.0	189+20%	SE02	7.8	40.0	88+20%	SE03	\$2,056	\$2,410
LM(E) 100L S6	2.00	50	13.10	1090	20.0	140.0	189+20%	SE01	10.2	40.0	88+20%	SE01	\$2,167	\$2,516

☉ S/L dual set of holes on base (actual frame is 90L) * Non-removable feet - side mount only (F2 standard/ F1 upon request)

LM MOTORS:
LM type motors are designed for no load or low starting torque applications such as fan duty. LM motors have two windings connected in parallel with a run capacitor connected in series giving the motor considerable overload capacity and high power factor. Please call for availability.

LME MOTORS:
LME type motors are designed for high torque applications. LME motors feature a capacitor start and capacitor run making them suitable for most applications (i.e. Gearboxes, pumps, machine tools.)



Frame sizes 71-112 have removable feet.

DVE - Single Phase Motors (Dual Voltage)



60 HZ Dual Voltage

1.0 Service Factor (SF) • 115V/230V • TEFC • Squirrel Cage
 F2 Lead Box (F0 or F1 Available for Frame Sizes 71 and Above)
 Class F • IP54 • IEC - CEI - UNEL MEC - CSA approved

Dimensions: Pages 25 & 29
 Connection Diagram: Page 17

2 POLE - 3600 RPM

Part Number	HP	115/230V Full Load Amps	Rated Torque Nm	Speed Min ⁻¹	Run Cap (µf)	Start Cap (µf)	Current Relay	Weight (lbs)	Price (\$)
DVE 63 C2 *	0.15	2.4/1.2	0.32	3300	16.0	53+20%	SE01	11	\$1,003
DVE 63 S2 *	0.25	3.2/1.6	0.51	3320	10.0	30+20%	SE02	12	\$1,020
DVE 63 L2 *	0.33	3.5/1.7	0.70	3330	16.0	53+20%	SE01	13	\$1,056
DVE 71 C2	0.50	7.0/3.5	1.00	3380	25.0	53+20%	SE01	16	\$1,209
DVE 71 S2	0.75	7.5/4.0	1.52	3450	20.0	53+20%	SE02	19	\$1,299
DVE 80 C2	1.00	13.0/6.5	2.10	3450	31.5	108+20%	SE01	26	\$1,495
DVE 80 S2	1.50	14.7/7.3	3.20	3300	50.0	161+20%	SE01	30	\$1,617
DVE 90S C2 ●	1.50	19.6/10.0	3.00	3440	70.0	124+20%	SE02	34	\$1,874
DVE 90L S2 ●	2.00	22.0/11.0	4.30	3350	40.0	124+20%	SE02	40	\$2,018
DVE 90L L2 ●	2.50	24.0/12.5	5.00	3450	40.0	161+20%	SE02	42	\$2,176
DVE 90L A2 ●	3.00	31.5/16.5	6.15	3420	60.0	161+20%	SE02	43	\$2,396
DVE 100L C2	3.00	25.8/14.3	6.20	3405	50.0	161+20%	SE01	55	\$2,480

4 POLE - 1800 RPM

Part Number	HP	115/230V Full Load Amps	Rated Torque Nm	Speed Min ⁻¹	Run Cap (µf)	Start Cap (µf)	Current Relay	Weight (lbs)	Price (\$)
DVE 63 A4 *	0.15	2.6/1.3	0.70	1640	25.0	53+20%	SE02	10	\$1,003
DVE 63 C4 *	0.25	3.2/1.6	1.05	1660	8.0	30+20%	SE02	11	\$1,046
DVE 71 C4	0.33	4.8/2.4	1.35	1720	12.5	30+20%	SE02	16	\$1,179
DVE 71 S4	0.40	7.0/3.5	1.70	1630	12.5	25+20%	SE02	19	\$1,222
DVE 71 L4	0.50	6.5/3.2	2.10	1715	25.0	53+20%	SE02	19	\$1,324
DVE 80 C4	0.50	6.0/3.0	2.05	1710	50.0	124+20%	SE01	22	\$1,424
DVE 80 S4	0.75	7.8/3.6	3.20	1660	16.0	53+20%	SE01	25	\$1,465
DVE 80 L4	1.00	10.8/5.4	4.20	1700	40.0	124+20%	SE01	29	\$1,520
DVE 90L D4 ●	1.50	16.2/8.2	6.20	1660	40.0	108+20%	SE02	34	\$1,908
DVE 90L E4 ●	2.00	20.5/10.3	8.50	1680	50.0	124+20%	SE02	39	\$2,061
DVE 100L C4	2.50	26.0/13.0	10.10	1700	50.0	124+20%	SE02	51	\$2,473
DVE 100L S4	3.00	30.0/15.0	12.40	1690	60.0	324+20%	SE02	53	\$2,645

6 POLE - 1200 RPM

Part Number	HP	115/230V Full Load Amps	Rated Torque Nm	Speed Min ⁻¹	Run Cap (µf)	Start Cap (µf)	Current Relay	Weight (lbs)	Price (\$)
DVE 71 C6	0.25	3.8/1.9	1.50	1100	25	53+20%	SE02	18	\$1,698
DVE 80 C6	0.33	4.6/2.3	2.10	1150	40	108+20%	SE02	20	\$1,843
DVE 80 S6	0.50	5.9/3.0	3.10	1150	50	124+20%	SE02	23	\$2,013
DVE 90L C6 ●	0.75	9.0/4.5	4.80	1100	25	64+20%	SE02	37	\$2,700
DVE 90L S6 ●	1.00	11.0/5.5	6.50	1100	50	88+20%	SE02	40	\$2,870
DVE 100L C6 +	1.50	15.8/7.9	9.10	1150	170	189+20%	SE02	42	\$2,994
DVE 100L S6 ++	2.00	20.0/10.0	13.10	1090	140	189+20%	SE02	50	\$3,131

● S/L dual set of holes on base (actual frame is 90L)
 * Non-removable feet - side mount only (F2 standard/ F1 upon request)
 + A total of 3 run capacitors are being used (50µf+50µf+70µf)
 ++ A total of 2 run capacitors are being used (70µf+70µf)



Frame sizes 71-100 have removable feet.

LA - IP56 Stainless Steel Motors



“Wash-down Protection”

Ideal for Food Processing and Pharmaceutical Industries

1.15 Service Factor (SF) • IEC 63 to 80 Frame Sizes in 2, 4 & 6 Poles • 230/460V (50/60 Hz) or 333/575V (60 Hz)

All Stainless Steel 300 Construction • IP56 Wash Down • Class F Insulation • Drain Holes at 90° Position

B3, B14 or B5 Mounting • Laser etched nameplate and paint free housing • TENV • CSA safety approvals

Turn Down Ratio 4:1 CT 10:1 • VT F2 Lead Box (standard) • Sanitary • Double Gaskets in Conduit Box

2 POLE - 3600 RPM

Part Number	Enclosure	HP	Full Load Amps		Rated Torque Nm	Speed Min ⁻¹	Weight (lbs)	Price (\$)
			460 V	575 V				
LA63S2	TENV	0.33	0.53	0.43	0.68	3455	18	\$896
LA71C2	TENV	0.50	0.75	0.60	1.01	3515	26	\$1,021
LA71S2	TENV	0.75	1.05	0.84	1.52	3500	31	\$1,065

4 POLE - 1800 RPM

Part Number	Enclosure	HP	Full Load Amps		Rated Torque Nm	Speed Min ⁻¹	Weight (lbs)	Price (\$)
			460 V	575 V				
LA63S4	TENV	0.25	0.53	0.43	1.02	1740	18	\$888
LA71C4	TENV	0.33	0.58	0.47	1.34	1750	19	\$1,026
LA71S4	TENV	0.50	0.75	0.60	2.04	1745	24	\$1,067
LA80C4	TENV	0.75	1.10	0.88	3.02	1765	39	\$1,288



Connection Diagram: Page 58

6 POLE - 1200 RPM

Part Number	Enclosure	HP	Full Load Amps		Rated Torque Nm	Speed Min ⁻¹	Weight (lbs)	Price (\$)
			460 V	575 V				
LA71C6	TENV	0.25	0.66	0.53	1.55	1145	23	\$1,199
LA71S6	TENV	0.33	0.78	0.62	2.05	1145	25	\$1,249
LA80C6	TENV	0.50	0.88	0.70	3.09	1150	40	\$1,477
LA80S6	TENV	0.75	1.20	0.95	4.64	1150	45	\$1,670

FLS B5 Flanges

Part Number	Price (\$)
FLS 63B5	149.00
FLS 71B5	254.00
FLS 80B5	271.00

FLS B14 Flanges

Part Number	Price (\$)
FLS 63B14	143.00
FLS 71B14	238.00
FLS 80B14	268.00

NOTE: Lowest 1 of 8 drain plugs must be removed to allow proper drainage. (4 drain plugs located on front end-bell and 4 located on non-drive end-bell)

IM B3 & IM B34 - C Flange

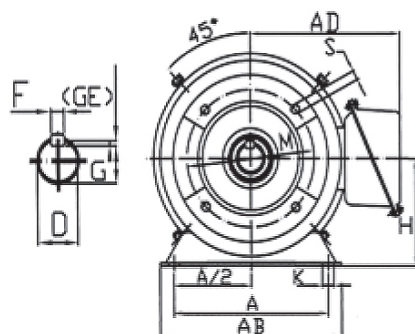

IM B5 - D Flange

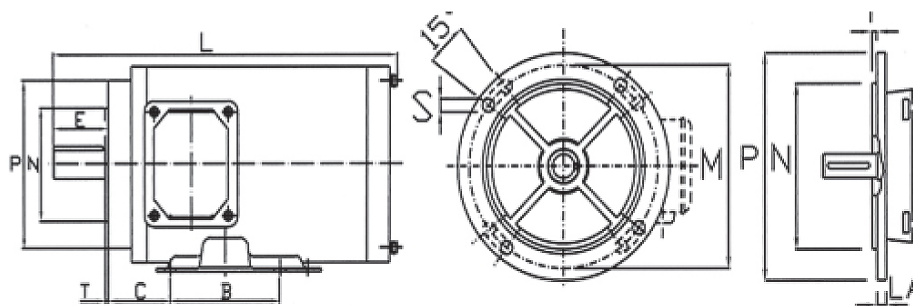

(Totally Enclosed Non-Ventilated)

Dimensions in mm

Motor Type															B14 FLANGE					B5 FLANGE				
	A	A/2	B	C	D	E	F	G	H	K	AB	AC	AD	L	M	N	P	S	T	M	N	P	S	T
LA 63	100	55.0	80	40	11	23	4	8.5	63	7	125	114	112	241	75	60	90	M5	2.5	115	95	140	10	3.0
LA 71	112	56.0	90	45	14	30	5	11.0	71	7	140	134	122	278	85	70	105	M6	2.5	130	110	160	10	3.5
LA 80	125	62.5	100	50	19	40	6	15.5	80	10	150	144	127	322	100	80	120	M6	3.0	165	130	200	12	3.5

LA - IP67 / IP69K Stainless Steel Motors



“Ultra / Steam Jet Protection”

1.15 Service Factor (SF) • IE1 (0.25HP to 0.75HP) & IE3 (1HP & Above) in 2 & 4 Poles • 230/460V (50/60 Hz) or 333/575V (60 Hz)
 All Stainless Steel 304 Construction (Shaft is SS420 Steel Grade) • Laser Etched Nameplate • Thermistors (150°C) • F0 Lead Box
 Class F Insulation • B3, B14 or B5 Mounting • TENV or TEFC • Round Lead Box • Stainless Steel Cable Glands
 1 Meter of 4 Core Double Insulated Cable • Turn Down Ratio 3:1CT & 10:1 VT • CSA Safety Approval • IE3 CSA Energy Verified



Connection Diagram: Page 58

2 POLE - 3600 RPM

Part Number	Enclosure	HP	Full Load Amps		Rated Torque Nm	Speed Min ⁻¹	Weight (lbs)	Price (\$)
			460 V	575 V				
LA 63 1-2	TENV	0.25	0.35	0.30	0.50	3430	23	\$943
LA 63 2-2	TENV	0.35	0.48	0.38	0.70	3420	25	\$983
LA 71 1-2	TENV	0.50	0.69	0.56	1.02	3450	31	\$1,138
LA 71 2-2	TENV	0.75	1.00	0.88	1.53	3430	32	\$1,188
LA 80 1-2 *	TENV	1.00	1.36	1.09	2.08	3450	47	\$1,704
LA 80 2-2 *	TENV	1.50	1.95	1.60	3.03	3470	53	\$1,755
LA 90S 1-2 *	TEFC	2.00	2.40	2.06	4.12	3475	66	\$2,482
LA 90L 1-2 *	TEFC	3.00	3.50	2.98	6.05	3475	66	\$2,488
LA 100L 1-2 *	TEFC	4.00	4.60	3.63	8.22	3485	110	\$3,086
LA 112M 1-2 *	TEFC	5.50	6.00	5.20	11.04	3460	137	\$5,628
LA 132S 1-2 *	TEFC	7.50	8.10	6.44	14.84	3540	187	\$7,125
LA 132S 2-2 *	TEFC	10.00	10.90	8.72	20.23	3540	187	\$7,223
LA 132M 1-2 *	TEFC	15.00	15.90	12.72	30.26	3535	220	\$9,896

4 POLE - 1800 RPM

Part Number	Enclosure	HP	Full Load Amps		Rated Torque Nm	Speed Min ⁻¹	Weight (lbs)	Price (\$)
			460 V	575 V				
LA 63 2-4	TENV	0.25	0.48	0.38	1.01	1700	25	\$1,004
LA 71 1-4	TENV	0.35	0.58	0.48	1.37	1740	31	\$1,123
LA 71 2-4	TENV	0.50	0.83	0.65	2.03	1740	33	\$1,188
LA 80 1-4	TENV	0.75	1.24	0.96	3.04	1730	45	\$1,433
LA 80 2-4 *	TENV	1.00	1.62	1.26	4.14	1730	50	\$1,744
LA 90S 1-4 *	TEFC	1.50	1.90	1.56	5.99	1755	66	\$2,404
LA 90L 1-4 *	TEFC	2.00	2.60	2.10	8.19	1750	68	\$2,461
LA 100L 1-4 *	TEFC	3.00	3.70	3.47	12.01	1750	106	\$3,333
LA 100L 2-4 *	TEFC	4.00	5.10	4.63	16.37	1750	110	\$3,379
LA 112M 1-4 *	TEFC	5.50	6.00	5.73	21.77	1755	137	\$5,662
LA 132S 1-4 *	TEFC	7.50	9.00	7.90	29.84	1760	198	\$7,135
LA 132M 1-4 *	TEFC	10.00	12.10	10.20	40.70	1760	198	\$7,819
LA 132M 2-4 *	TEFC	15.00	16.90	14.50	60.60	1765	243	\$8,601

* Premium Efficiency

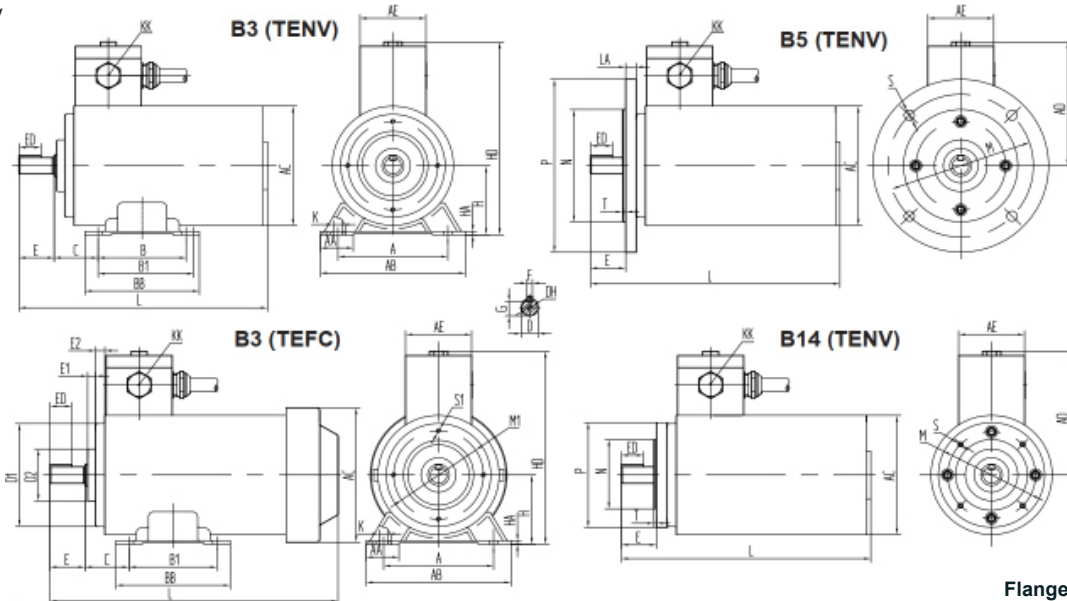

Flange List: Page 23
 Dimensions in mm

Modular Flanges

Frame (H)	A	AA	AB	BB	HA	B	B1	C	D	D1	D2	DH	E	E1	E2	F	G	HD	K	KK METRIC	AE	LA	ED	L TENV	L TEFC
63	100	32	132	110	4	80	N/A	40	11	95	45	M3	23	11.5	20.0	4	8.5	190	7	2-M20x1.5	65	15	13	265	300
71	112	30	140	120	4	90	N/A	45	14	108	50	M4	30	10.0	26.5	5	11.0	205	7	2-M20x1.5	65	15	20	290	335
80	125	37.5	165	130	4	100	N/A	50	19	119	60	M6	40	6.5	10.5	6	15.5	230	10	2-M20x1.5	75	12	25	323	360
90	140	40	180	165	4	100	125	56	24	135	80	M6	50	7.5	15.0	8	20.0	255	10	2-M20x1.5	75	12	40	375	415
100	160	45	205	180	4	140	N/A	63	28	150	76	M10	60	7.5	7.0	8	24.0	280	12	2-M20x1.5	85	12	45	430	480
112	190	60	250	180	5	140	N/A	70	28	166	76	M10	60	7.0	28.0	8	24.0	315	13	2-M25x1.5	85	12	45	440	495
132	216	60	276	218	5	140	178	89	38	200	93	M12	80	11.5	24.0	10	33.0	350	13	2-M25x1.5	85	16	63	555	617

Frame (H)	AD	AC TENV	AC TEFC	M1	S1	M	N	B5 P	S	T	M	N	B14 P	S	T
63	128	119	133	78	M6	115	95	140	10	3.5	75	60	95	M5	2.5
71	135	129	150	90	M6	130	110	160	10	3.5	85	70	105	M6	2.5
80	150	139	165	102	M6	165	130	200	12	3.5	100	80	120	M6	3.0
90	160	164	190	115	M6	165	130	200	12	3.5	115	95	140	M8	3.0
100	185	186	210	96	M6	215	180	250	15	4.0	130	110	160	M8	3.5
112	203	220	240	96	M6	215	180	250	15	4.0	130	110	160	M8	3.5
132	215	261	280	153	M8	265	230	300	15	4.0	165	130	200	M10	4.0

Standard Motor Parts
Cooling Fans & Fan Covers



Cooling Fans						
	Motor Type	Frame Size	Part Number	Dimensions (mm)		Price (\$)
				Bore	OD	
ALUMINUM	ST/ LM(E)/ DVE	56	XVA000040000	9	85	\$154
		63	XVA000110000	14	90	\$212
	ST/ AM/ LM(E)/ DVE	71	XVA003220000	14	128	\$228
		80	XVA003320000	19	143	\$287
	ST/ LM(E)/ DVE	90	XVA003420000	24	162	\$312
		100 / 112	XVA003540000	28	180	\$338
132		XVA000710000	40	230	\$425	
		160	XVA000810000	45	270	\$519
PLASTIC	ST/ LM(E)/ DVE	56	XVN003060000	9	90	\$96
		63	XVN003160000	14	110	\$96
	ST/ AM/ LM(E)/ DVE	71	XVN003260000	14	128	\$112
		80	XVN003310000	19	135	\$112
	AMPH	80	XVN003350000	19	110	\$112
	ST/ LM(E)/ DVE	90	XVN003410000	24	155	\$119
		90	XVN003450000	24	135	\$119
	AMPH	90L (DA2)	XVN003470000	24	129	\$119
		100 (2 Pole)	XVN003550000	28	135	\$179
	ST/ LM(E)/ DVE/ AMPH	100 / 160	XVN003520000	28	164	\$179
	ST/ LM(E)/ DVE	112	XVN003610000	28	190	\$179
		112	XVN003650000	28	135	\$179
	AMPH	132 (2 Pole)	XVN003750000	40	135	\$312
		132	XVN003770000	40	164	\$312
	ST	132	XVN00081	40	220	\$312

NOTE:

Fans for newer designed motors may vary. Please check with the technical department for specific requirements.

Metal fans are pressure die-cast aluminum.

Plastic fans are glass reinforced at 160°C polypropylene.

Fan Covers						
	Motor Type	Frame Size	Part Number	Dimensions (mm)		Price (\$)
				Depth	OD	
METAL	ST/ LM(E)/ DVE	56	XCR007020000	52	110	\$49
		63	XCR007120000	52	124	\$49
	ST/ AM/ LM(E) / AMPH	71	XCR007220000	67	139	\$52
		80	XCR007320000	68	156	\$66
	ST/ LM(E)/ DVE	90	XCR007420000	70	180	\$87
		100	XCR007520000	85	195	\$95
	AMPH	100 (2 Pole)	XCR00051-AMPH	120	195	\$95
		100 (4-6 Pole) +	XCR007570000 +	195	195	\$95
		112	XCR007620000	95	222	\$131
		112M (DA2)	XCR007660000	120	220	\$131
		132S ++	XCR00071-S ++	90	250	\$166
		132M ++	XCR00071-M ++	130	250	\$166
		132L ++	XCR00071-L ++	190	250	\$166
		160M	XCR00081-AMPH160M	130	315	\$208
		160L	XCR00081-AMPH160L	150	315	\$343
PLASTIC	ST/ LM(E)/ DVE	56	XCR007010000	52	110	\$49
		63	XCR0007110000	58	124	\$49
	ST/ AM/ LME(E)/ DVE	71	XCR0007210000	67	139	\$52
		80	XCR0007310000	65	156	\$66
	ST/ AMPH	90	XCR0007410000	70	180	\$87
	ST/ LM(E)	100	XCR0007510000	85	195	\$95
	ST/ LM(E)/ AMPH	90	XCR0007410000	70	180	\$87
		90L (DA2)	XCR00045-AMS	92	180	\$87
	AMPH	112M (DA2)	XCR007660000	120	220	\$131
112		XCR0007610000	95	222	\$131	

+ Available in square design only

++ Verify dimensions prior to order as there are some exceptions

For frame sizes 180 to 315, or any other parts not listed here, please contact Lafert NA.

Range of Flanges



All Flanges are Machined for Shaft Oil Seals

M = Center to center bolt hole circle

N= Spigot diameter

Dimensions in mm

Aluminum Flanges

ST, AM,FB, AAF, AMBZ, MS, LM(E), DVE, AMPH Motors

B5 'D' Flange	M	N	Price (\$)	B14 'C' Flange	M	N	Price (\$)
FL56B5	100	80	\$113	FL56B14	65	50	\$113
FL63B5	115	95	\$113	FL63B14	75	60	\$113
FL71B5	130	110	\$113	FL71B14	85	70	\$113
FL80B5	165	130	\$141	FL80B14	100	80	\$126
FL90B5	165	130	\$167	FL90B14	115	95	\$141
FL100B5 *	215	180	\$235	FL100B14 *	130	110	\$211
FL112B5	215	180	\$235	FL112B14	130	110	\$227
FL132B5	265	230	\$433	FL132B14	165	130	\$312
FL160B5	300	250	\$636	FL160B14	215	180	\$591

* AMPH 100 frame motors in 4 & 6 pole require H4 flanges

Dimensions: Page 29

Cast Iron Flanges

LAB Motors

B5 'D' Flange	M	N	Price (\$)	B14 'C' Flange	M	N	Price (\$)
FLD132B5	265	230	\$353	FLD132B14	165	130	\$254
FLD160B5	300	250	\$519	FLD160B14	215	180	\$482
FLD180B5	300	250	\$524				
FLD200B5	350	300	\$865				
FLD225B5	400	350	\$1,393				
FLD250B5	500	450	\$1,466				
FLD280B5	500	450	\$1,780				
FLD315B5	600	550	\$2,571				

Dimensions: Page 30

**Permanent Magnet Motor (HPS)
Flanges - Page 24**

Increased and Reduced Aluminum Flanges

ST, AM, FB, AAF, AMBZ, MS, LM(E), DVE, AMPH Motors

B5 Reduced	Price (\$)	B5 Increased	Price (\$)	B14 Reduced	Price (\$)	B14 Increased	Price (\$)
FL63B5R56	\$160	FL63B5I71	\$171	FL63B14R56	\$171	FL56B14I63	\$171
FL71B5R56	\$160	FL71B5I80	\$211	FL71B14R63	\$171	FL63B14I71	\$171
FL71B5R63	\$160			FL80B14R63	\$190	FL63B14I80	\$190
FL80B5R63	\$197			FL80B14R71	\$190	FL71B14I80	\$190
FL80B5R71	\$197			FL90B14R71	\$211	FL71B14I90	\$211
FL90B5R71	\$235			FL90B14R80	\$211	FL80B14I90	\$211
FL100B5R71	\$331			FL100B14R90	\$316	FL80B14I100	\$316
FL100B5R80	\$331			FL112B14R90	\$354	FL90B14I100	\$316
FL100B5R90	\$331			FL132B14R100	\$468	FL100B14I132	\$468
FL112B5R90 *	\$331			FL132B14R112	\$468	FL112B14I132	\$468
FL132B5R112	\$608			FL160B14R132**	\$887		
FL160B5R132 **	\$891						

*** AMPH 100 frame motors in 4 & 6 pole require H4 flanges

Dimensions: Page 29

* Shaft machining required at additional cost.

** 160M Frame: shaft extension and bearing repositioning is required at additional cost.

160L Frame: shaft extension is required at additional cost.

NOTE: Please inquire for all B5 increased/reduced flanges as they may require motor customization. An additional charge may be applicable.

Stainless Steel Flange Adapter Plates

LA Motors (IP67 & IP69K)

B5 'D' Flange	M	N	Price (\$)	B14 'C' Flange	M	N	Price (\$)
FLP63B5	115	95	\$214	FLP63B14	75	60	\$145
FLP71B5	130	110	\$261	FLP71B14	85	70	\$139
FLP80B5	165	130	\$290	FLP80B14	100	80	\$139
FLP90B5	165	130	\$347	FLP90B14	115	95	\$151
FLP100B5	215	180	\$486	FLP100B14	130	110	\$191
FLP112B5	215	180	\$486	FLP112B14	130	110	\$191
FLP132B5	265	230	\$955	FLP132B14	165	130	\$359

IP56 Flanges: Page 20

IP67 / IP69K Dimensions: Page 21

Explosion Proof Flanges

MAK Motors

B5 'D' Flange	M	N	Price (\$)	B14 'C' Flange	M	N	Price (\$)
FLEX56B5	100	80	\$530	FLEX56B14	65	50	\$530
FLEX63B5	115	95	\$530	FLEX63B14	75	60	\$530
FLEX71B5	130	110	\$530	FLEX71B14	85	70	\$530
FLEX80B5	165	130	\$625	FLEX80B14	100	80	\$625
FLEX90B5	165	130	\$689	FLEX90B14	115	95	\$689
FLEX100B5	215	180	\$858	FLEX100B14	130	110	\$858
FLEX112B5	215	180	\$1,034	FLEX112B14	130	110	\$1,034
FLEX132B5	265	230	\$1,158	FLEX132B14	165	130	\$1,158
FLEX160B5	300	250	\$1,332	FLEX160B14	215	180	\$1,332
FLEX180B5	300	250	\$1,468				
FLEX200B5	350	300	\$1,597				
FLEX225B5	400	350	\$1,773				
FLEX250B5	500	450	\$2,080				

Dimensions: Page 35

NEMA flanges available

HPS - High Performance Permanent Magnet Synchronous Motors



IM B3 / IM B14 / IM B5 / NEMA C-Flange Dimensions (Aluminum Frame)

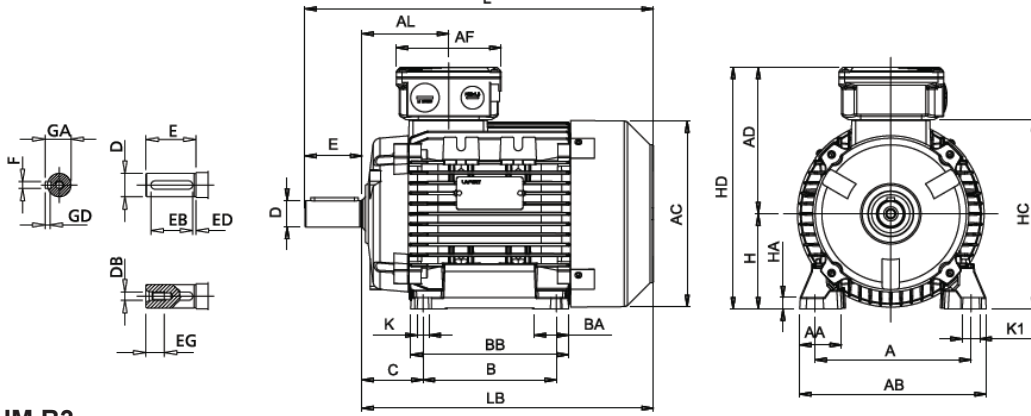

(N)** = NEMA
 1) Clearance hole for screw
 2) Maximum dimension
 3) Centering holes in shaft extensions to DIN 332 part 2

IM B3

H (Frame)	A	B	C	K ⁽¹⁾	AB	BB	AD ⁽²⁾	HD ⁽²⁾	AC	HC	HA	K1	L	L(N)**	LB	LB (N)**
56	90	71	36	6	107	86	92	148	110	109	8	9	188	-	168	-
71	112	90	45	8	135	108	114	185	142	142	9	17	245	10.433"	215	8.386"
90 S/L	140	100/125	56	10	170	150	148	238	177	181	11	15	317	12.638"	267	10.512"
112 M	190	140	70	12.5	220	176	171	283	225	226	15	19	388	15.669"	328	13.051"
112 XL	190	140	70	12.5	220	176	171	283	225	226	15	19	410	16.535"	350	13.917"
132 M	216	178	89	12	256	218	195	327	248	261	17	20	485	19.055"	405	15.945"
132 XL	216	178	89	12	256	218	195	327	248	261	17	20	505	19.852"	425	16.732"
132 XXL	216	178	89	12	256	218	195	327	248	261	17	20	556	21.860"	476	18.740"
160 M	254	210	108	14	320	270	238	398	317	316	23	18	608	-	498	-
160 L	254	254	108	14	320	310	238	398	317	316	23	18	652	-	542	-

H (Frame)	AL	AF	BA	AA	D	D(N)**	E	E(N)**	F	F(N)**	GD	GA	DB ⁽³⁾	EG	EB	EB (N)**	ED
56	61	93	27	27	14	-	30	-	5	-	5	16	M5	12.5	20	-	4
71	75	93	22	30	19 j6	0.625"	40	2.06"	6	0.188"	6	22	M6	16	30	1.41"	4
90 S/L	85	110	28/53	37	24 j6	0.875"	50	2.12"	8	0.188"	7	27	M8	19	40	1.41"	4
112 M	92	110	46	48	28 j6	1.125"	60	2.62"	8	0.25"	7	31	M10	22	50	1.78"	4
112 XL	92	110	46	48	28 j6	1.125"	60	2.62"	8	0.25"	7	31	M10	22	50	1.78"	4
132 M	122	133	45	59	38 k6	1.375"	80	3.12"	10	0.312"	8	41	M12	28	70	2.41"	4
132 XL	122	133	45	59	38 k6	1.375"	80	3.12"	10	0.312"	8	41	M12	28	70	2.41"	4
132 XXL	122	133	45	59	38 k6	1.375"	80	3.12"	10	0.312"	8	41	M12	28	70	2.41"	4
160 M	146	150	65	76	42 k6 *	-	110	-	12 *	-	8 *	45 *	M16	36	100	-	4
160 L	168	150	65	76	48 k6	-	110	-	14	-	9	51.5	M16	36	100	-	4

* For HPS 160M in 18.5kW, refer to HPS 160L dimension

IM B14 - C Flange

IM B5 - D Flange

NEMA - C Flange

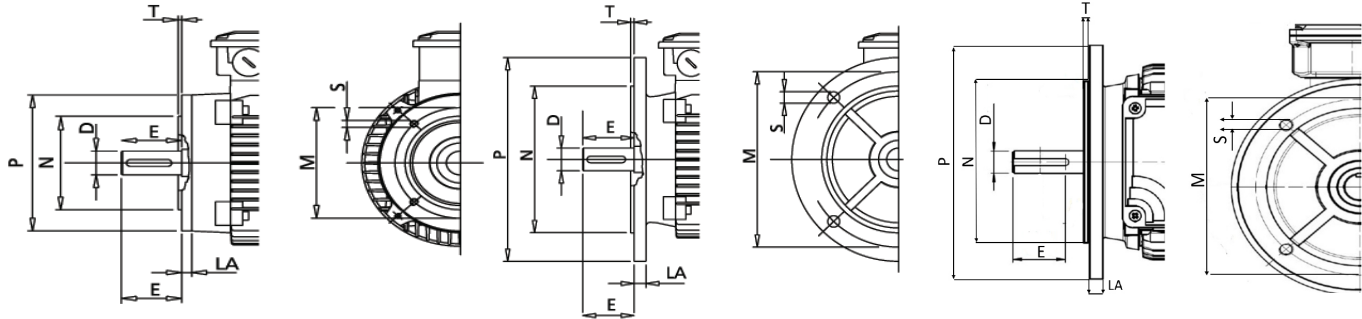

Frame	Dimensions in Millimeters												Dimensions in Inches											
	B14 FLANGE						B14 FLANGE (Increasing)						B5 FLANGE						NEMA C-FLANGE					
	P	N	LA	M	T	S ⁽¹⁾	P	N	LA	M	T	S ⁽¹⁾	P	N	LA	M	T	S ⁽¹⁾	P	N	LA	M	T	S ⁽¹⁾
56	80	50	8	65	2.5	M5	105	70	8	85	2.5	M6	120	80	7	100	2.5	M6	-	-	-	-	-	-
71	105	70	11	85	2.5	M6	140	95	8	115	3	M8	160	110	10	130	3.5	M8	6.5"	4.5"	0.354"	5.875"	0.16"	3/8"
90 S/L	140	95	10	115	3.0	M8	160	110	9	130	3.5	M8	200	130	12	165	3.5	M10	6.5"	4.5"	0.472"	5.875"	0.16"	3/8"
112 M/XL	160	110	10	130	3.5	M8	200	130	12	165	3.5	M10	250	180	14	215	4.0	M12	9"	8.5"	0.459"	7.25"	0.25"	1/2"
132 M/XL/XXL	200	130	23	165	3.5	M10	250	180	12	215	4	M12	300	230	14	265	4.0	M12	9"	8.5"	0.36"	7.25"	0.25"	1/2"
160 M/L	250	180	20	216	4.0	M12	300	230	12	265	5	M16	350	250	15	300	5.0	M16	-	-	-	-	-	-

Permanent Magnet Motors require oversized bearing flanges. Please contact a Lafert N.A sales representative for details.

IM B3 Dimensions (Aluminum Frame)

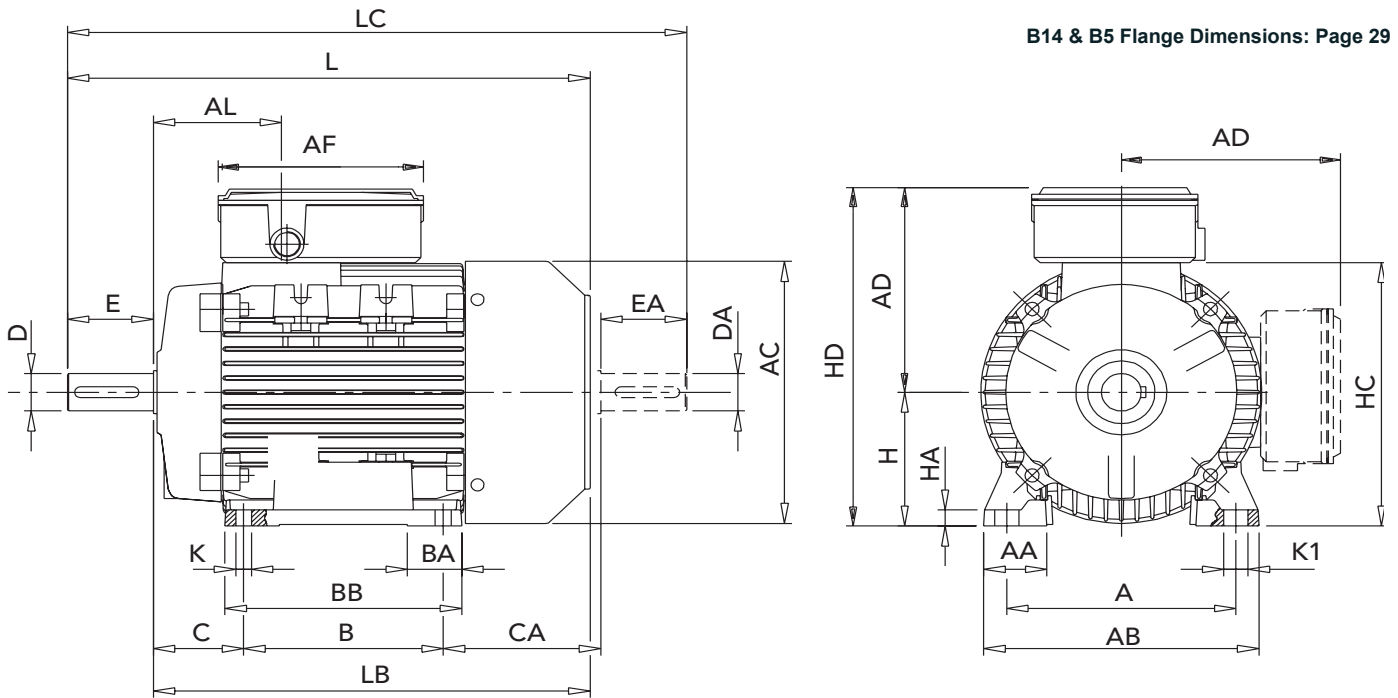

B14 & B5 Flange Dimensions: Page 29

• F2 (right side) LEAD BOX (F0 or F1 available on request)

NON-DRIVE END SHAFT IS OPTIONAL LC, EA, DA

IM B3 - DVE / LME Series (56-112M frame) & LM (56-80 frame)

Dimensions in mm

H (Frame)	A	B	C	K	AB	BB	CA	AD	HD	AC	HC	HA	K1	L	LB	LC	AL	AF	BA	AA	D/DA	E/EA	F	GD	GA	DB	EG	EB
56 *	90	71	36	6	107	86	63	98	154	104	110	8	9	189	169	210	68	143	27	27	9	20	3	3	10.2	M3	7.5	15
63 *	100	80	40	7	120	100	73	105	168	122	122	8	11	214	191	239	66	143	28	30	11	23	4	4	12.5	M4	10.5	15
71	112	90	45	7	135	109	80	119	190	142	144	9	11	243	213	275	73	143	28	31	14	30	5	5	16	M5	12.5	20
80	125	100	50	9	154	125	89	131	211	160	162	10	14	277	237	319	99	168	35	33	19	40	6	6	21.5	M6	19	30
90S	140	100	56	9	170	125	101	140	230	180	181	11	15	307	257	357	103	168	37	37	24	50	8	7	27	M8	19	40
90L	140	125	56	9	170	150	101	140	230	180	181	11	15	332	282	382	103	168	37	37	24	50	8	7	27	M8	19	40
100L	160	140	63	11	192	166	110	147	247	195	200	12	17	373	313	433	107	168	42	44	28	60	8	7	31	M10	22	50
112M	190	140	70	12	220	175	126	163	275	222	226	15	19	394	334	456	109	168	46	48	28	60	8	7	31	M10	22	50

* Non-removable feet - side mount only (F2 standard/ F1 upon request)

IM B3 Dimensions (Aluminum Frame)

B5 & B14 Flange Dimensions: Page 29

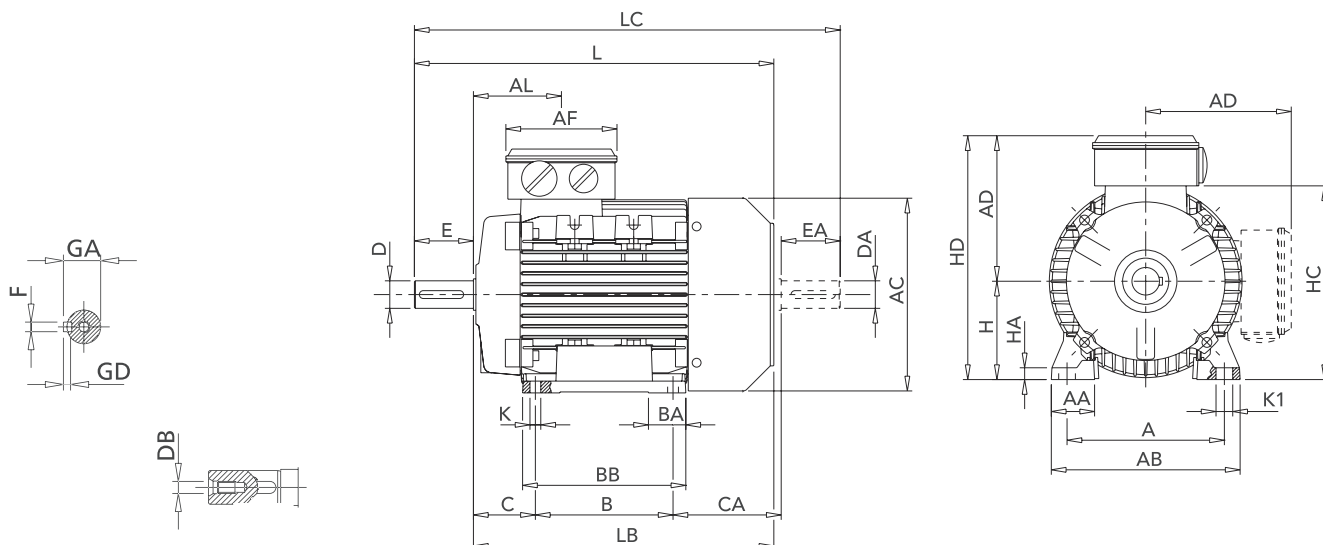

• F2 (right side) LEAD BOX (F0 or F1 available on request)

NON-DRIVE END SHAFT IS OPTIONAL LC, EA, DA

IM B3 - AM / ST / FB

Dimensions in mm

Frame	H	A	B	C	K ¹⁾	AB	BB	AD ²⁾	HD ²⁾	AC	HC	HA	K1	AL	AF	BA	AA	D/DA	E/EA	F	GD	GA	DB ³⁾	CA	L	LB	LC
56 *	90	71	36	6	107	86	92	148	110	109	8	9	61	92	27	27	9	20	3	3	3	10.2	M3	64	188	168	211
63 *	100	80	40	7	120	100	96	159	124	120	8	11	63	92	29	30	11	23	4	4	4	12.5	M4	72	211	188	238
71	112	90	45	8	135	108	110	181	139	142	9	11	69	92	28	31	14	30	5	5	5	16	M5	83	246	216	278
80	125	100	50	10	153	125	129	209	160	162	9.5	14	79	116	28.5	34.5	19	40	6	6	6	21.5	M6	89	272	232	319
90S	140	100	56	10	170	150	138	228	180	181	11	15	85	116	53	37	24	50	8	7	7	27	M8	116	317	267	372
90L	140	125	56	10	170	150	138	228	180	181	11	15	85	116	53	37	24	50	8	7	7	27	M8	91	317	267	372
100	160	140	63	11	192	166	145	245	196	198	12	17	92	116	38	44	28	60	8	7	7	31	M10	110	366	306	433
112	190	140	70	12.5	220	175	161	273	225	226	15	19	92	116	46	48	28	60	8	7	7	31	M10	126	388	328	456
132S	216	140	89	12	256	180	195	327	248	261	17	20	100	133	45	59	38	80	10	8	8	41	M12	134	442	362	523
132M	216	178	89	12	256	218	195	327	248	261	17	20	120	133	45	59	38	80	10	8	8	41	M12	136	482	402	563
132M ⁴⁾	216	178	89	12	256	218	195	327	248	261	17	20	120	133	45	59	38	80	10	8	8	41	M12	166	500	420	593
160M	254	210	108	14	320	270	238	398	317	316	23	18	146	150	65	76	42	110	12	8	8	45	M16	180	608	498	718
160L	254	254	108	14	320	310	238	398	317	316	23	18	168	150	65	76	42	110	12	8	8	45	M16	180	652	542	762
160L ⁵⁾	254	254	108	14	320	310	238	398	317	316	23	18	168	150	65	76	42	110	12	8	8	45	M16	210	678	568	678

* Non-removable feet - side mount only (F2 standard/ F1 upon request)

1) Clearance hole for screw 2) Maximum dimension 3) Centering holes in shaft extensions to DIN 332 part 2 4) Only for MT A2 5) Only for LD A4

IM B3 Dimensions (Aluminum Frame)

B14 & B5 Flange Dimensions: Page 29

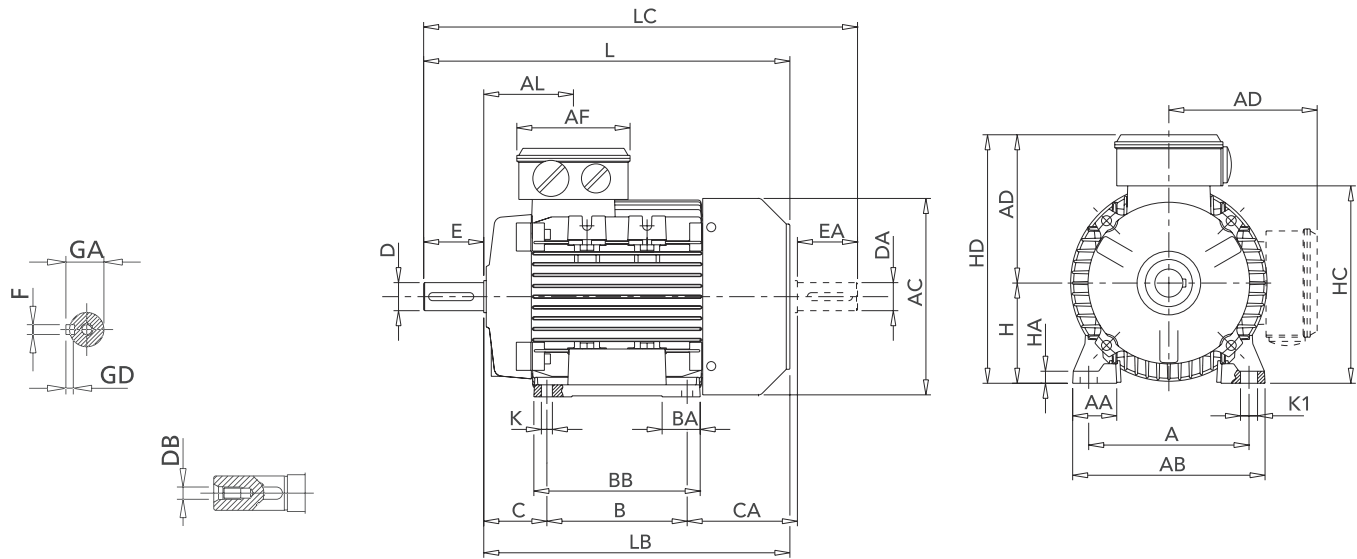

• F2 (right side) LEAD BOX (F0 or F1 available on request)

NON-DRIVE END SHAFT IS OPTIONAL LC, EA, DA

IM B3 - AMPH Series

Dimensions in mm

Frame H	Pole	HP	A	B	C	K ¹⁾	AB	BB	AD ²⁾	HD ²⁾	AC	HC	HA	K1	AL	AF	BA	AA	D/DA	E/EA	F	GD	GA	DB ³⁾	CA	L	LB	LC
80	2-4	all	125	100	50	10	153	125	140	220	160	162	9.5	14	79	116	28.5	34.5	19	40	6	6	21.5	M6	89	272	232	319
90S	2-4	all	140	100	56	10	170	150	149	239	180	181	11	15	85	116	53	37	24	50	8	7	27	M8	116	317	267	372
	6	1.0	140	100	56	10	170	150	149	239	180	181	11	15	85	116	53	37	24	50	8	7	27	M8	116	317	267	372
90L	2	3.0	140	125	56	10	170	150	149	239	180	181	11	15	85	116	53	37	24	50	8	7	27	M8	91	317	267	372
	2	4.0	140	125	56	10	170	150	138	239	180	181	11	15	85	116	53	37	24	50	8	7	27	M8	114	340	290	395
	4	all	140	125	56	10	170	150	149	239	180	181	11	15	85	116	53	37	24	50	8	7	27	M8	91	317	267	372
100L	2	all	160	140	63	11	192	166	156	256	196	198	12	17	91	110	38	44	28	60	8	7	31	M10	110	366	306	433
	4-6	all	160	140	63	11	192	166	156	256	198	192	12	17	92	118	41	44	28	60	8	7	31	M10	110	366	306	433
112M	2	5.5-7.5	190	140	70	12.5	220	176	172	284	225	225	15	19	92	116	46	48	28	60	8	7	31	M10	126	388	328	456
	2	10.0	190	140	70	12.5	220	176	172	284	225	225	15	19	92	116	46	48	28	60	8	7	31	M10	148	410	350	478
	4	all	190	140	70	12.5	220	176	172	284	225	225	15	19	92	116	46	48	28	60	8	7	31	M10	126	388	328	456
	6	1.5	190	140	70	12.5	220	176	172	284	225	225	15	19	92	116	46	48	28	60	8	7	31	M10	126	388	328	456
	6	2.0-2.4	190	140	70	12.5	220	176	172	284	225	225	15	19	92	116	46	48	28	60	8	7	31	M10	148	410	350	478
132S	2	7.5	216	140	89	12	256	180	194	326	248	261	17	20	102	133	45	59	38	80	10	8	41	M12	134	445	365	523
	2	10.0	216	140	89	12	256	180	194	326	248	261	17	20	102	133	45	59	38	80	10	8	41	M12	154	465	385	543
	4	7.5	216	140	89	12	256	180	194	326	248	261	17	20	102	133	45	59	38	80	10	8	41	M12	174	485	405	563
	6	3.0-4.0	216	140	89	12	256	180	194	326	248	261	17	20	102	133	45	59	38	80	10	8	41	M12	154	465	385	543
132M	2	12.4-15.0	216	178	89	12	256	218	194	326	248	261	17	20	122	133	45	59	38	80	10	8	41	M12	156	505	425	583
	2	20.0	216	178	89	12	256	218	194	326	248	261	17	20	122	133	45	59	38	80	10	8	41	M12	207	556	476	640
	4	10.0	216	178	89	12	256	218	194	326	248	261	17	20	122	133	45	59	38	80	10	8	41	M12	156	505	425	583
	4	12.4	216	178	89	12	256	218	194	326	248	261	17	20	122	133	45	59	38	80	10	8	41	M12	207	556	476	640
	6	5.5	216	178	89	12	256	218	194	326	248	261	17	20	122	133	45	59	38	80	10	8	41	M12	136	485	405	563
160M	2-6	all	254	210	108	14	320	270	238	398	317	316	23	18	146	150	65	76	42/28	110/60	12/8	8/7	45	M16	180	608	498	668
160L	2-6	all	254	254	108	14	320	310	238	398	317	316	23	18	168	150	65	76	42/28	110/60	12/8	8/7	45	M16	180	652	542	712

1) Clearance hole for screw

2) Maximum dimension

3) Centering holes in shaft extensions to DIN 332 part 2

IM B3 Dimensions (Aluminum Frame)

B14 & B5 Flange Dimensions: Page 29

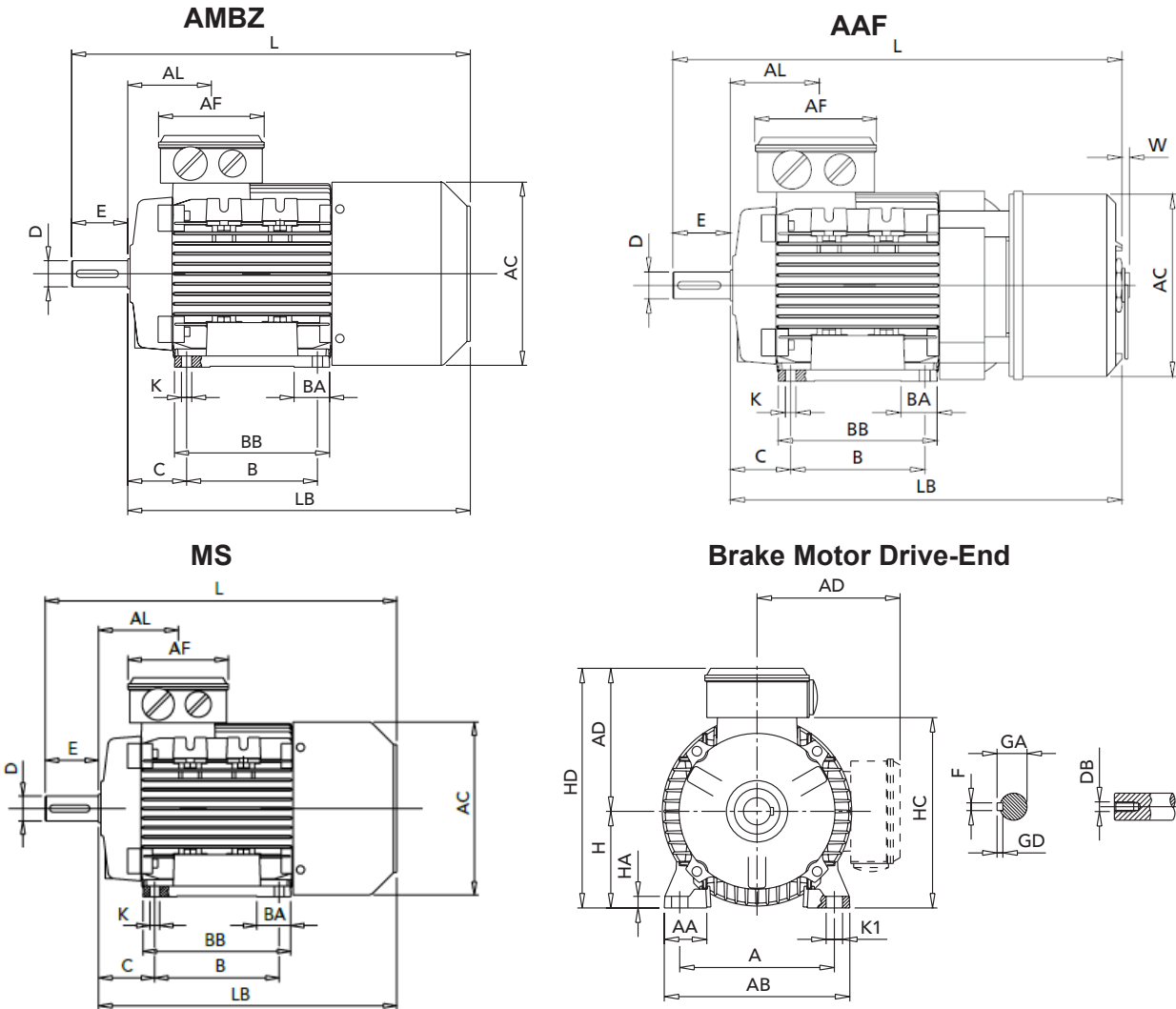

IM B3

Dimensions in mm

AMBZ / MS - manual release lever optional (side of motor)
 AAF - manual release key included (rear of motor)

• F2 (right side) LEAD BOX (F0 or F1 available on request)

(Frame)														AMBZ			AAF				MS *										
	H	A	B	C	K ¹⁾	AB	BB	AD ²⁾	HD ²⁾	HC	HA	K1	AL	AF	BA	AA	D	E	F	GD	GA	DB ³⁾	AC	L	LB	AC	L	LB	W	AC	L
63	100	80	40	7	120	100	96	159	120	8	11	63	92	29	30	11	23	4	4	12.5	M4	124	267	244	126	302	279	6	124	226	203
71	112	90	45	8	135	108	110	181	142	8	11	69	92	28	31	14	30	5	5	16	M5	138	300	270	142	336	306	5	139	255	225
80	125	100	50	10	153	125	129	208	161	9.5	14	79	116	29	35	19	40	6	6	21.5	M6	156	350	310	160	384	344	5	157	294	254
90S	140	100	56	10	170	150	137	227	180	11	15	85	116	53	37	24	50	8	7	27	M8	178	403	353	179	435	385	4	177	340	290
90L	140	125	56	10	170	150	137	227	180	11	15	85	116	53	37	24	50	8	7	27	M8	178	403	353	179	435	385	4	177	340	290
100	160	140	63	11	192	166	144	244	197	12	17	91	116	38	44	28	60	8	7	31	M10	192	465	405	197	479	419	6	196	379	319
112	190	140	70	12.5	220	176	160	272	225	15	19	92	116	46	48	28	60	8	7	31	M10	222	487	427	224	507	447	6	222	396	336
132S	216	140	89	12	256	180	194	326	261	17	20	100	133	45	59	38	80	10	8	41	M12	259	592	512	263	613	533	8	248	480	400
132M	216	178	89	12	256	218	194	326	261	17	20	120	133	45	59	38	80	10	8	41	M12	259	612	532	263	633	553	8	248	500	420
160M	254	210	108	14	320	270	237	397	317	23	18	146	150	65	76	42	110	12	8	45	M16	316	721	611	258	784	674	-	316	614	504
160L	254	254	108	14	320	310	237	397	317	23	18	168	150	65	76	42	110	12	8	45	M16	316	763	653	258	806	696	-	316	658	548
160L ⁴⁾	254	254	108	14	320	310	237	397	317	23	18	168	150	65	76	42	110	12	8	45	M16	316	790	680	-	-	-	-	-	-	-

1) Clearance hole for screw 4) Only for LD A4
 2) Maximum dimension
 3) Centering holes in shaft extensions to SIN 332 part 2

* Please Inquire: MS Compact brake motor non-drive end shaft is not standard size.

IM B14 / IM B5 - Flange Dimensions

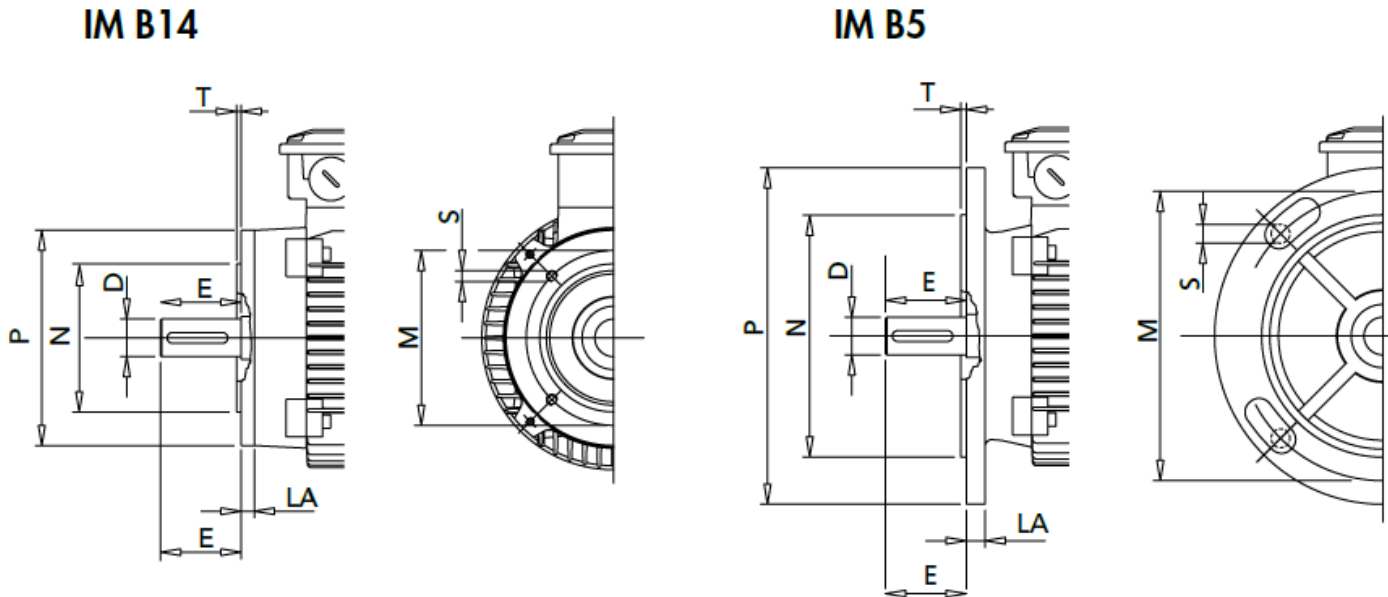

IM B14 - C Flange & IM B5 - D Flange

Dimensions in mm

M = Center to center bolt hole circle N = Spigot diameter P = Outside diameter

Frame	B14						B14 Reduced Frame	B14 Increased Frame	B5						B5 Reduced Frame	B5 Increased Frame
	M	N	P	S	T	LA			M	N	P	S	T	LA		
56	65	50	80	M5	2.5	8	-	63	100	80	120	7	2.5	7	-	-
63	75	60	90	M5	2.5	8	56	71/80	115	95	140	9.5	3	8	56	71
71	85	70	105	M6	2.5	8	63	80/90	130	110	160	9.5	3.5	10	63/56	80/90
80	100	80	120	M6	3	9	71/63	90/100	165	130	200	11.5	3.5	10	71/63	-
90	115	95	140	M8	3	9	80/71	100/112	165	130	200	11.5	3.5	12	71	-
100	130	110	160	M8	3.5	10	90	132	215	180	250	14	4	14	90/80/71	-
112	130	110	160	M8	3.5	10	90	132	215	180	250	14	4	14	90 *	-
132	165	130	200	M10	3.5	30	112/100	-	265	230	300	14	4	14	112	-
160	215	180	250	M12	4	12	132 **	-	300	250	350	18	5	15	132 **	-

* Shaft machining required at additional cost.

** 160M Frame: shaft extension and bearing repositioning is required at additional cost.

160L Frame: shaft extension is required at additional cost.

NOTE: Please inquire for all B5 increased/reduced flanges as they may require motor customization. An additional charge may be applicable.

Mounting (132-315 Cast Iron Frames) Dimensions

IM B3

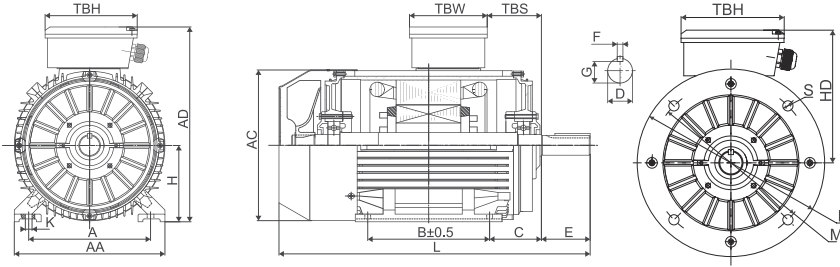

IM B5 - D Flange

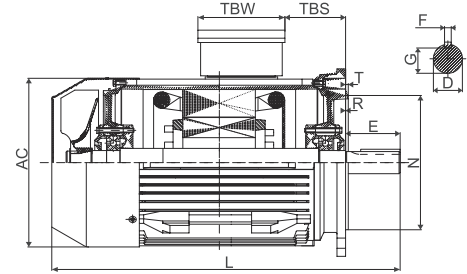

IM B35

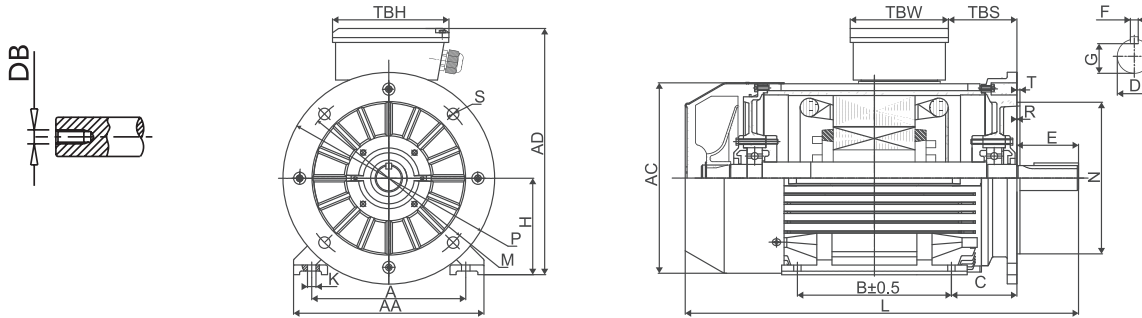

Installation & Overall Dimensions

Dimensions in mm

• F0 Lead Box

Frame	H	Poles	Foot Mounting			Shaft					General					Terminal Box			
			A	B	C	D	E	F	DB	G	K	AA	AD	HD	AC	L	TBS	TBW	TBH
132 M	8		216	178	89	38	80	10	M12	33	12	270	345	210	275	560	48	108	116
160 M/L	2,4,6,8		254	210/254	108	42	110	12	M16	37	15	320	420	255	330	670/700	69	150	160
180 M/L	2,4,6,8		279	241/279	121	48	110	14	M16	42.5	15	348	455	275	380	700/740	81	150	160
200 L	2,4,6,8		318	305	133	55	110	16	M20	49	19	388	505	305	420	770	92	188	208
225 S	4,6,8		356	286	149	60	140	18	M20	53	19	436	560	335	470	815	95	188	208
225 M	2		356	311	149	55	110	16	M20	49	19	436	560	335	470	820	95	188	208
	4,6,8		356	311	149	60	140	18	M20	53	19	436	560	335	470	845	95	188	208
250 M	2		406	349	168	60	140	18	M20	53	24	484	615	365	510	910	99	216	246
	4,6,8		406	349	168	65	140	18	M20	58	24	484	615	365	510	910	99	216	246
280 S/M	2		457	368/419	190	65	140	18	M20	58	24	557	680	400	580	985/1035	107	216	246
	4,6,8		457	368/419	190	75	140	20	M20	67.5	24	557	680	400	580	985/1035	107	216	246
315 S	2		508	406	216	65	140	18	M20	58	28	630	845	530	645	1270	117	280	320
	4,6,8		508	406	216	80	170	22	M20	71	28	630	845	530	645	1270	117	280	320
315 M/L	2		508	457/508	216	65	140	18	M20	58	28	630	845	530	645	1300	117	280	320
	4,6,8		508	457/508	216	80	170	22	M20	71	28	630	845	530	645	1300	117	280	320

Frame	H	Poles	Bearings			M	N	B5		
			Drive End	Non-Drive End	Cable Gland			P	S	T
132 M	8		6308 C3	6308 C3	M32x1.5	265	230	300	4-14	4
160 M/L	2,4,6,8		6309 C3	6309 C3	M40x1.5	300	250	350	4-18	5
180 M/L	2,4,6,8		6311 C3	6311 C3	M40x1.5	300	250	350	4-19	5
200 L	2,4,6,8		6312 C3	6312 C3	M40x1.5	350	300	400	4-19	5
225 S/M	2,4,6,8		6313 C3	6313 C3	M50x1.5	400	350	450	8-19	5
250 M	2,4,6		6314 C3	6314 C3	M63x1.5	500	450	550	8-19	5
	2		6314 C3	6314 C3	M63x1.5	500	450	550	8-19	5
280 S/M	4,6		6317 C3	6317 C3	M63x1.5	500	450	550	8-19	5
	2		6317 C3	6317 C3	M63x1.5	600	550	660	8-24	6
315 S/L	4,6		NU319	6319 C3	M63x1.5	600	550	660	8-24	6

Product Information

Gases, Vapours & Groups [ATEX and IECEx]

Combustible gases and vapors are divided into classes according to their ignition temperature and into groups according to their explosive capacity. Symbolic markings on motors and other electrical equipment are used to indicate the production mode, the enclosure group, and the temperature class, which allows us to understand the zone in which such equipment can be installed.

Group	Environment	Location	Typical Substance
I	Gases, Vapours and Coal Dust	Coal Mining	Methane (fire damp)
IIA	Gases, Vapours and Mists	Surface and other locations	Methane, Propane, etc.
IIB			Ethylene
IIC			Hydrogen, Acetylene, etc.
IIIA	Combustible Dusts	Surface and other locations	Combustible flyings
IIIB			Non-conductive
IIIC			Conductive

Typical ATEX & IECEx Nomenclature

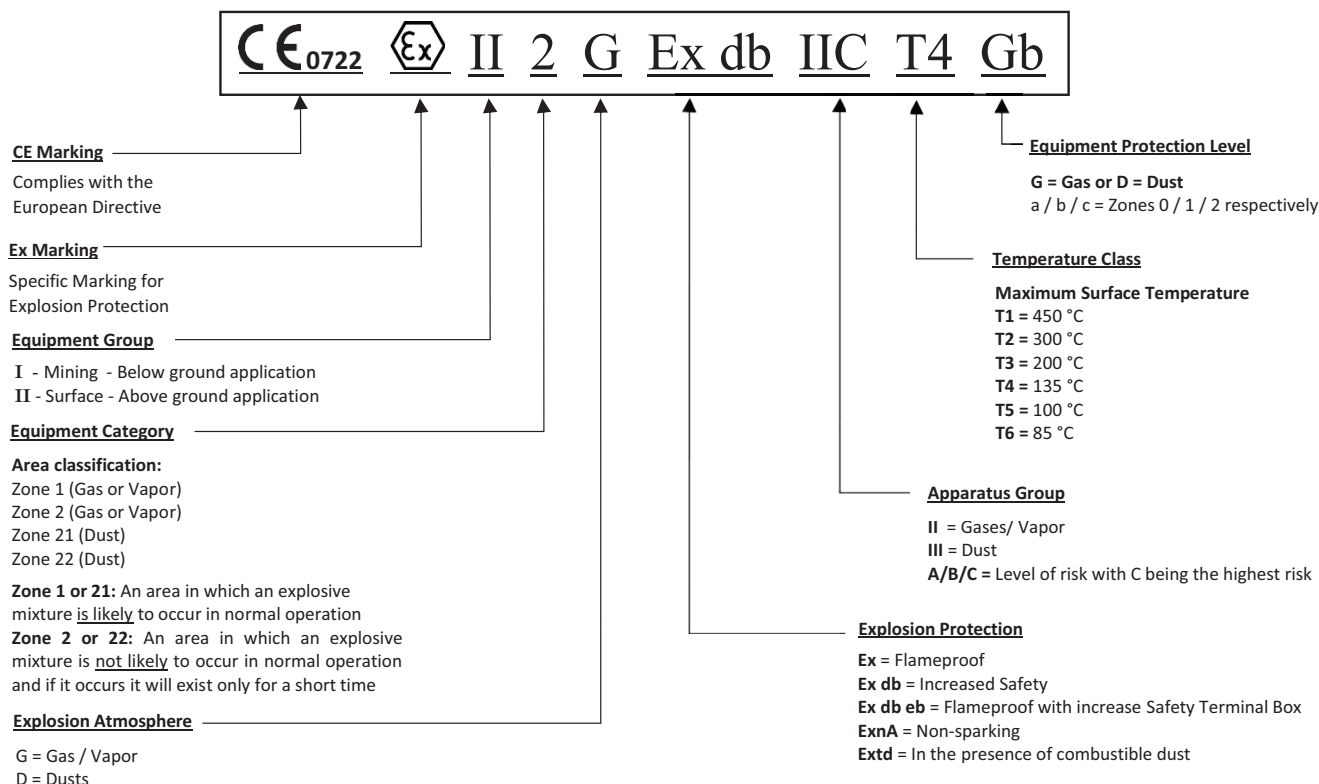

Zone Classification

Usage area in the presence of GAS	Usage area in the presence of DUSTS	Hazardous level of the operational ZONE
Zone 0	Zone 20	Explosive atmosphere ALWAYS PRESENT
Zone 1	Zone 21	Explosive atmosphere PROBABLE
Zone 2	Zone 22	Explosive atmosphere UNLIKELY

Temperature Classification

Ignition Temperature of Medium (relative to limit temperature)	Temperature Class	Maximum Surface Temperature of Electrical Equipment (including 40° C ambient temperature)	
		[°C]	[°F]
over 450	T1	450	842
from 300 to 450	T2	300	572
from 200 to 300	T3	200	392
from 135 to 200	T4	135	275
from 100 to 135	T5	100	212
from 85 to 100	T6	85	185

Product Information

Special Features & Optional Types	Flameproof Motor Purchasing Checklist
<p>Typical Variants</p> <ul style="list-style-type: none"> • Motors with brakes • 2GD motors for areas classified as zone 21 and zone 22 (Dust) <p>Electrical Variants</p> <ul style="list-style-type: none"> • Non-standard voltages and frequencies (maximum voltage 1000V) • Motors suitable for frequency inverter drive • Motors with encoder • Motors with forced ventilation (from frame size 80) • Motors for tropical climates • Motors for low ambient temperatures • Motors insulated to class H • Motors with bimetallic detector; thermistor PTC or thermistor PT100 • Motors with anti-condensation heaters • Motors with special electrical design • Single-phase motors with capacitor fitted in a large size terminal box (EEx-d, max 59 µF) <p>Mechanical Variants</p> <ul style="list-style-type: none"> • Special flanges and shafts • Double ended shafts • Cable gland fitted to terminal box • Terminal box with special cable entries • Motors without terminal box and with loose cables • Ingress protection IP56 - IP65 - IP66 • Motors with condensation drainage valves • Motors with special bearing (uni-directional, with sensors, with rollers, insulated, oversized, thrust bearings) • Motors with a rain cap or sun shield, water-shedding disc • Low noise emission version 	<p>Power Rating _____ kW</p> <p>Synchronous Speed _____ RPM</p> <p>Phase _____ Ph</p> <p>Frequency _____ Hz</p> <p>Voltage _____ V</p> <p>Destination (Country) _____</p> <p>Starting & Control _____ D.o.L _____ VFD</p> <p>Torque _____ Constant _____ Variable</p> <p>Protection Scheme _____ TEFC _____ Ex db _____ Ex db eb _____ Ex'na</p> <p>Temperature Class T _____ (1,2,3,4,5 or 6)</p> <p>Zone Classification _____ (Gas 1 or 2) _____ (Dust 21 or 22)</p> <p>Grouping _____ (I, IIA, IIB, IIC)</p> <p>Insulation Class _____ Class F</p> <p>Temperature Rise _____ Class B</p> <p>Ambient Temperature _____ (40°C, 45°C, 50°C, 55°C)</p> <p>IP rating IP _____ (IP55, IP56, IP other)</p> <p>IC Rating _____ IC411 _____ IC416 _____ IC _____</p> <p>Paint Standard _____ C2 _____ C3 _____ C4 _____ C5i Other: _____</p> <p>Finish Colour _____ RAL 5010 (standard) Other: _____</p> <p>Main Terminal Box (MTB) _____ F0 _____ F _____</p> <p>Termination IEC 60034-8 _____ Standard Terminal Block _____ Flying Leads</p> <p>Bearings Arrangement _____ Anti Friction Ball _____ Roller Type _____ Sealed Other: _____</p> <p>Mounting _____ B3 Foot Mounted _____ B5 _____ B14 _____ B34 _____ B35 _____ V1</p> <p>Service Factor _____ 1.0 _____ 1.15</p> <p>Certifications _____ ATEX _____ IEC ex (On Request) Other: _____</p> <p>Efficiency Classification _____ IE1 Standard High _____ IE2 ePACT _____ IE3 Efficient (Europe)</p> <p>Special Features _____ Thermistors _____ Thermostats _____ 100 Ω platinum RTDs _____ 2-phase wired to MTB _____ Space Heaters _____ V AC Other: _____</p>
<p>Explosion Proof Motors 1HP & Higher do <u>NOT</u> meet the North American Energy Efficiency Regulations. Our Explosion Proof Motors are ATEX Certified only (no CSA/UL Certification available).</p> <p><i>See below for exemptions.</i></p>	
<p>Exemptions for use in North America</p> <p><i>Efficiency Regulations can be exempt per the following conditions:</i></p>	
a. Motors that are rated for a Duty cycle of S2 to S9 (intermittent duty)	
b. Motors that are to be powered by independent power source, not a local utility.	
c. Single phase motors	
d. 2 speed motors	
<p><i>Note: Motors that will be for export outside of North America or used in offshore applications are not required to meet North American Regulations.</i></p>	

MAK - Explosion Proof Motors



Product Information

230/460V or 333/575V, 50 Hz or 60 Hz • Threaded Hole in Output Shaft • TEFC • Squirrel Cage • Class F • Cast Iron (F0 Lead Box)
 IP55 Flameproof Enclosure • Ex db IIC T4 Gb ATEX Certification • Single Phase, 2 Speed & Brake Motor Designs Available • Class 'B' Rise
 No CSA or UL Certification Provided • Thermistors for Continuous Torque Applications • Alternate Protection Levels Available
 Non-sparking (Class 1 Div. 1) motors are also available.

2 POLE - 3600 RPM

Part Number	ATEX CERTIFIED		Weight (lbs)	Full Load Amps		Rated Torque Nm
	Kw	HP		460 V	575 V	
MAK056BP2	0.12	0.18	15	0.31	0.25	0.44
MAK063AP2	0.18	0.25	22	0.45	0.36	0.62
MAK063BP2	0.25	0.33	24	0.69	0.55	0.86
MAK071AP2	0.37	0.50	33	0.77	0.62	1.23
MAK071BP2	0.55	0.75	35	1.08	0.86	1.90
MAK080AP2	0.75	1.00	49	1.41	1.13	2.51
MAK080BP2	1.10	1.50	53	2.11	1.69	3.67
MAK090SP2	1.50	2.00	64	2.63	2.10	4.97
MAK090LP2	2.20	3.00	69	3.49	2.80	7.33
MAK100LWP2	3.00	4.00	99	5.31	4.25	9.84
MAK112MP2	4.00	5.50	123	6.64	5.31	13.05
MAK132SAP2	5.50	7.50	157	8.93	7.14	17.90
MAK132SBP2	7.50	10.00	174	11.69	9.35	24.46
MAK132MAP2	9.20	12.50	216	14.26	11.41	30.15
MAK132MBP2	11.00	15.00	216	17.14	13.71	36.07
MAK160MAP2	11.00	15.00	287	17.19	13.75	35.69
MAK160MBP2	15.00	20.00	326	23.29	18.64	48.69
MAK160LP2	18.50	25.00	362	27.68	22.14	59.91
MAK180MP2	22.00	30.00	489	32.27	25.82	71.24
MAK200LAP2	30.00	40.00	758	44.26	35.41	96.79
MAK200LBP2	37.00	50.00	809	53.67	42.94	119.29
MAK225MP2	45.00	60.00	1003	65.52	52.42	144.07
MAK250MP2	55.00	75.00	1168	82.47	65.98	176.38

4 POLE - 1800 RPM

Dimensions: Page 34 & 35

Part Number	ATEX CERTIFIED		Weight (lbs)	Full Load Amps		Rated Torque Nm
	Kw	HP		460 V	575 V	
MAK056BP4	0.09	0.12	16	0.29	0.23	0.64
MAK063AP4	0.12	0.18	23	0.41	0.33	0.84
MAK063BP4	0.18	0.25	26	0.57	0.45	1.26
MAK063CP4	0.25	0.33	26	0.83	0.66	1.80
MAK071AP4	0.25	0.33	35	0.63	0.51	1.70
MAK071BP4	0.37	0.50	37	0.87	0.70	2.51
MAK080AP4	0.55	0.75	52	1.33	1.06	3.68
MAK080BP4	0.75	1.00	54	1.63	1.30	5.00
MAK090SP4	1.10	1.50	65	2.28	1.82	7.28
MAK090LP4	1.50	2.00	70	3.04	2.43	9.98
MAK100LWP4	2.20	3.00	100	4.55	3.64	14.50
MAK100LXP4	3.00	4.00	105	5.85	4.68	19.84
MAK112MP4	4.00	5.50	135	7.57	6.06	26.31
MAK132SP4	5.50	7.50	175	10.06	8.05	35.95
MAK132MAP4	7.50	10.00	210	13.46	10.77	49.09
MAK132MBP4	9.20	11.80	226	16.69	13.35	60.50
MAK160MP4	11.00	15.00	310	19.45	15.56	71.36
MAK160LP4	15.00	20.00	365	25.96	20.77	97.52
MAK180MP4	18.50	25.00	495	33.33	26.66	119.78
MAK180LP4	22.00	30.00	541	38.91	31.13	142.54
MAK200LP4	30.00	40.00	755	47.6	38.08	194.77
MAK225SP4	37.00	50.00	960	58.57	46.86	239.23
MAK225MP4	45.00	60.00	1036	71.39	57.11	290.76
MAK250MP4	55.00	75.00	1246	85.49	68.39	353.94

6 POLE - 1200 RPM

Part Number	ATEX CERTIFIED		Weight (lbs)	Full Load Amps		Rated Torque Nm
	Kw	HP		460 V	575 V	
MAK056BP6	0.035	0.05	15	0.33	0.26	0.37
MAK063AP6	0.09	0.12	22	-	-	-
MAK063BP6	0.12	0.16	24	0.55	0.44	1.33
MAK071AP6	0.18	0.25	34	0.50	0.40	1.91
MAK071BP6	0.25	0.35	36	0.75	0.60	2.63
MAK080AP6	0.37	0.50	50	0.91	0.73	3.82
MAK080BP6	0.55	0.75	55	1.42	1.13	5.69
MAK090SP6	0.75	1.00	64	1.78	1.43	7.52
MAK090LP6	1.10	1.50	68	2.39	1.91	11.15
MAK100LP6	1.50	2.00	96	3.37	2.70	14.97
MAK112MP6	2.20	3.00	126	4.52	3.62	21.73
MAK132SP6	3.00	4.00	167	5.78	4.63	29.44
MAK132MAP6	4.00	5.50	200	7.76	6.21	39.26
MAK132MBP6	5.50	7.50	220	11.34	9.07	54.04
MAK160MP6	7.50	10.00	315	14.35	11.48	73.69
MAK160LP6	11.00	15.00	362	21.35	13.09	107.74
MAK180MP6	15.00	20.00	570	27.77	21.73	146.47
MAK200LAP6	18.50	25.00	774	34.03	27.23	179.55
MAK200LBP6	22.00	30.00	833	37.25	29.80	213.52
MAK225MP6	30.00	40.00	994	50.33	40.26	291.75
MAK250MP6	37.00	50.00	1235	63.37	50.70	358.00

8 POLE - 900 RPM

Part Number	ATEX CERTIFIED		Weight (lbs)	Full Load Amps		Rated Torque Nm
	Kw	HP		460 V	575 V	
MAK063P8	0.04	0.06	26	0.4	0.32	0.62
MAK071P8	0.09	0.12	34	0.73	0.58	1.20
MAK080AP8	0.18	0.25	50	0.77	0.62	2.44
MAK080BP8	0.25	0.33	55	0.97	0.78	3.44
MAK090SP8	0.37	0.50	64	1.5	1.20	4.99
MAK090LP8	0.55	0.75	70	1.77	1.42	7.49
MAK100LWP8	0.75	1.00	96	2.09	1.67	9.99
MAK100LXP8	1.10	1.50	103	3.21	2.57	14.73
MAK112MP8	1.50	2.00	128	3.91	2.40	20.35
MAK132SP8	2.20	3.00	172	4.77	3.81	29.10
MAK132MP8	3.00	4.00	206	6.61	5.29	39.63
MAK160MAP8	4.00	5.50	288	9.35	7.32	53.05
MAK160MBP8	5.50	7.50	315	11.39	9.11	72.25
MAK160LP8	7.50	10.00	363	15.58	12.47	98.25
MAK180LP8	11.00	15.00	570	21.52	17.22	143.71
MAK200LP8	15.00	20.00	795	28.11	22.49	195.70
MAK225SP8	18.50	25.00	917	34.6	27.68	240.70
MAK225MP8	22.00	30.00	992	21.18	16.95	285.85
MAK250MP8	30.00	40.00	1270	53.09	42.48	387.69

NORTH AMERICAN CERTIFICATION MUST BE OBTAINED BY USER

Explosion Proof Motors 1HP & higher do **NOT** meet North American Energy Efficiency Regulations - Exemptions: Page 32

IM B3 Dimensions

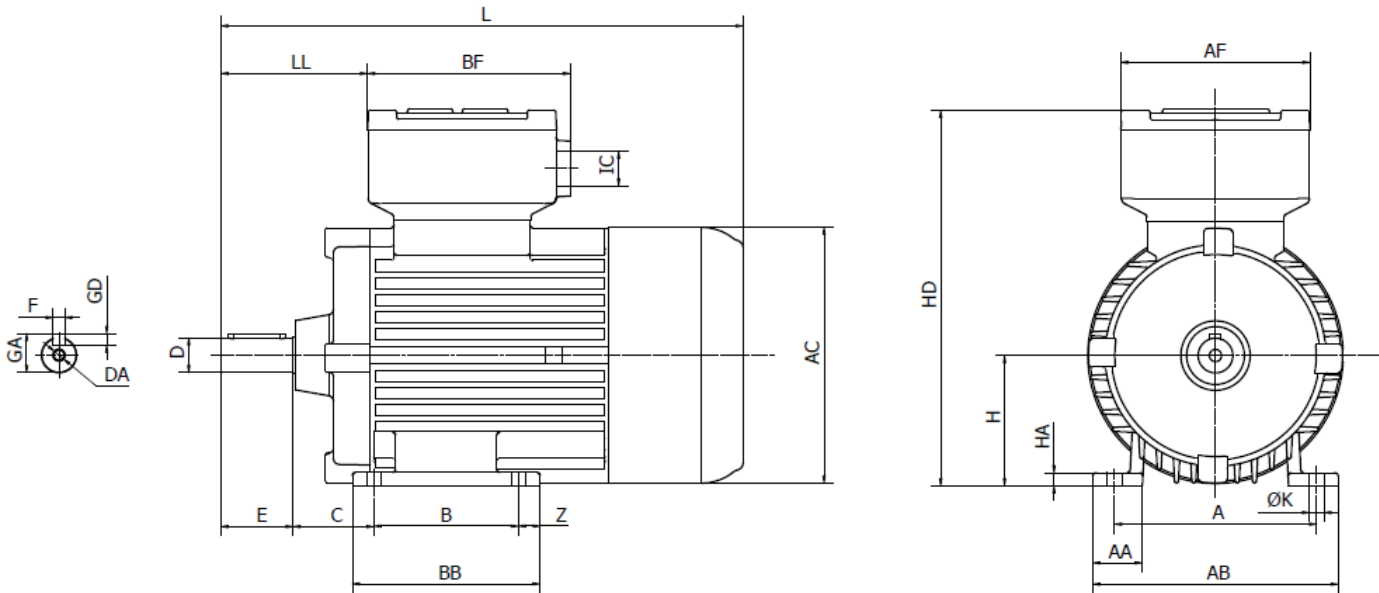

• F0 Lead Box

IM B3 - MAK Series

Dimensions in mm

Frame	A	AA	AB	AC	AF	B	BB	BF	C	D	DA	E	F	GA	GD	H	HA	HD	K	L	LL	Z	IC
56	90	23	105	110	91	71	90	104	36	9	M3	20	3	10.2	3	56	6	176	6	210	53	9	1xM20
63 A / B	100	30	120	123	101	80	100	114	40	11	M4	23	4	12.5	4	63	7	198	7	244	68	10	1xM20
71 A / B	112	32	140	139	101	90	110	114	45	14	M5	30	5	16.0	5	71	8	215	7	284	80	10	1xM20
80 A / B	125	39	155	157	131	100	130	141	50	19	M6	40	6	21.5	6	80	9	238	10	323	85	15	1xM25
90 S	140	34	170	177	131	100	130	141	56	24	M8	50	8	27.0	7	90	9	256	10	362	102	15	1xM25
90 L	140	34	170	177	131	125	155	141	56	24	M8	50	8	27.0	7	90	9	256	10	382	102	15	1xM25
100 L	160	45	196	196	131	140	170	141	63	28	M10	60	8	31.0	7	100	12	285	12	449	129	15	1xM25
112M	190	48	224	221	151	140	170	163	70	28	M10	60	8	31.0	7	112	12	318	12	452	128	15	1xM32
132S	216	60	260	260	151	140	180	163	89	38	M12	80	10	41.0	8	132	13	355	12	526	138	20	1xM32
132M	216	60	260	260	151	178	220	163	89	38	M12	80	10	41.0	8	132	13	355	12	566	138	22	1xM32
160M	254	75	306	317	201	210	260	219	108	42	M16	110	12	45.0	8	160	15	423	15	631	175	28	2xM32
160L	254	75	306	317	201	254	300	219	108	42	M16	110	12	45.0	8	160	15	423	15	671	175	24	2xM32
180M	279	83	341	348	201	241	303	215	121	48	M16	110	14	51.5	9	180	20	482	15	755	209	31	2xM32
180L	279	83	341	348	201	279	340	215	121	48	M16	110	14	51.5	9	180	20	482	15	795	209	30	2xM32
200L	318	93	380	385	262	305	370	286	133	55	M20	110	16	59.0	10	200	22	566	18	870	213	32	2xM50
225S	356	110	434	433	262	286	365	286	149	60	M20	140	18	64.0	11	225	25	611	19	917	248	50	2xM50
225M 2	356	110	434	433	262	311	390	286	149	55	M20	110	16	59.0	10	225	25	611	19	927	248	50	2xM50
225M 4-8	356	110	434	433	262	311	390	286	149	60	M20	140	18	64.0	11	225	25	611	19	957	248	50	2xM50
250M 2	406	122	486	480	262	349	425	286	168	60	M20	140	18	64.0	11	250	25	661	24	986	254	38	2xM50
250M 4-8	406	122	486	480	262	349	425	286	168	65	M20	140	18	69.0	11	250	25	661	24	986	254	38	2xM50

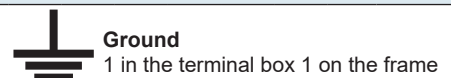

IM B34 & IM B35 Dimensions

IM B34

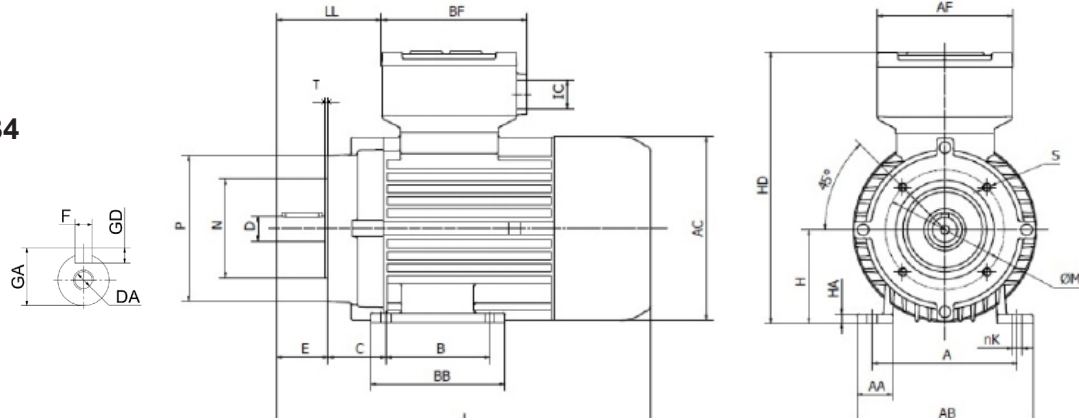

IM B35

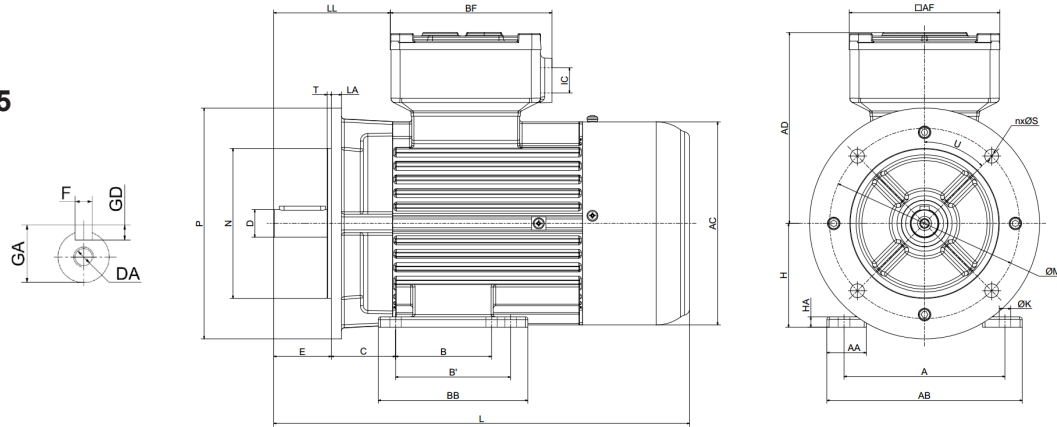

• F0 Lead Box

B34 = Motor with feet and B14 Flange
 B35 = Motor with feet and B5 Flange

IM B34 & IM B35

Dimensions in mm

Frame	B34															B35																
	A	AA	AB	AC	AD	AF	B	BB	BF	C	D	DA	E	F	GA	GD	L	LL	IC	K	M	N	p	S	T	LA						
56	90	23	105	110	120	91	71	90	104	36	9	M3	20	3	10.2	3	210	53	1xM20	6	65	50	80	M5	2.5	5.8	100	80	119	7	3	8
63	100	30	120	123	135	101	80	100	114	40	11	M4	23	4	12.5	4	244	68	1xM20	7	75	60	90	M5	2.5	7	115	95	140	10	3	8
71	112	32	140	139	144	101	90	110	114	45	14	M5	30	5	16.0	5	284	80	1xM20	7	85	70	105	M6	2.5	7	130	110	160	10	3.5	8
80	125	39	155	157	158	131	100	130	141	50	19	M6	40	6	21.5	6	323	85	1xM25	10	100	80	120	M6	3	10	165	130	200	12	3.5	9
90 S	140	34	170	177	166	131	100	130	141	56	24	M8	50	8	27.0	7	362	102	1xM25	10	115	95	140	M8	3	10	165	130	200	12	3.5	9
90 L	140	34	170	177	166	131	125	155	141	56	24	M8	50	8	27.0	7	382	102	1xM25	10	115	95	140	M8	3	10	165	130	200	12	3.5	9
100	160	45	196	196	185	131	140	170	141	63	28	M10	60	8	31.0	7	449	129	1xM25	12	130	110	160	M8	3.5	12	215	180	250	15	4	10
112M	190	48	224	221	206	151	140	170	163	70	28	M10	60	8	31.0	7	452	128	1xM32	12	130	110	160	M8	3.5	12	215	180	250	15	4	11
132S	216	60	260	260	223	151	140	180	163	89	38	M12	80	10	41.0	8	526	138	1xM32	12	165	130	200	M10	3.5	12	265	230	300	15	4	12
132M	216	60	260	260	223	151	178	220	163	89	38	M12	80	10	41.0	8	566	138	1xM32	12	165	130	200	M10	3.5	12	265	230	300	15	4	12
160M	254	75	306	317	263	201	210	260	219	108	42	M16	110	12	45.0	8	631	175	2xM32	15	215	180	250	M12	4	15	300	250	350	19	5	14
160L	254	75	306	317	263	201	254	300	219	108	42	M16	110	12	45.0	8	671	175	2xM32	15	215	180	250	M12	4	15	300	250	350	19	5	14
180M	279	83	341	348	302	201	241	303	215	121	48	M16	110	14	51.5	9	755	209	2xM32	*	*	*	*	*	*	15	300	250	350	19	5	15
180L	279	83	341	348	302	201	279	340	215	121	48	M16	110	14	51.5	9	795	209	2xM32	*	*	*	*	*	*	15	300	250	350	19	5	15
200L	318	93	380	385	366	262	305	370	286	133	55	M20	110	16	59.0	10	870	213	2xM50	*	*	*	*	*	*	18	350	300	400	19	5	18
225S	356	110	434	433	386	262	286	365	286	149	60	M20	140	18	64.0	11	917	248	2xM50	*	*	*	*	*	*	19	400	350	450	19	5	18
225M 2	356	110	434	433	386	262	311	390	286	149	55	M20	110	16	59.0	10	927	248	2xM50	*	*	*	*	*	*	19	400	350	450	19	5	18
225M 4-8	356	110	434	433	386	262	311	390	286	149	60	M20	140	18	64.0	11	957	248	2xM50	*	*	*	*	*	*	19	400	350	450	19	5	18
250M 2	406	122	486	480	411	262	349	425	286	168	60	M20	140	18	64.0	11	986	254	2xM50	*	*	*	*	*	*	24	500	450	550	19	5	18
250M 4-8	406	122	486	480	411	262	349	425	286	168	65	M20	140	18	69.0	11	986	254	2xM50	*	*	*	*	*	*	24	500	450	550	19	5	18

* For B14 flanges on frame sizes 132-160, please inquire with a Lafert N.A sales representative.

Note: B5 flanges size: 56-200 have 4 holes & size: 225-250 have 8 holes

SPV / IMM - Immersion Type Pumps (3-Phase)



Product Information

208-230/460V or 333/575V 60 Hz • 3600 RPM • SPV Pumps are cULus Approved
 Single-Phase Available (made on request with a typical lead time of 4-5 days)

Dimensions: Page 37
 Alternate Designs: Page 38

SPV Weight (lbs) for each Suction Height: Page 37

Part Number	HP	Full Load Amps		Suction Height B (mm)	Price (\$)
		460V	575V		
SPV 12	0.12	0.33	0.32	90-120-170-220-270-350	\$819
SPV 18	0.18	0.34	0.31	90-120-170-220-270-350	\$883
SPV 25	0.25	0.50	0.25	90-120-170-220-270-350	\$1,348
SPV 33	0.33	0.50	0.32	90-120-170-220-270-350	\$1,478
SPV 50	0.50	1.65	1.20	200-270-350-440*-550*	\$1,872
SPV 75	0.75	2.00	1.40	200-270-350-440*-550*	\$2,088
SPV 100	1.00	2.10	1.67	200-270-350-440*-550*	\$3,022
SPV 150	1.50	2.60	2.30	200-270-350-440*-550*	\$3,165

* SPV Pumps with suction height of 440 & 550 are cast iron



Part Number	HP	Full Load Amps		Suction Height B (mm)	Weight (lbs)	Price (\$)
		460V	575V			
IMM 90 A	2.0	5.0	3.9	350	105	\$4,903
				450	107	\$5,106
				600	108	\$5,309
				800	111	\$5,484
IMM 90 B	3.0	6.2	4.9	350	109	\$5,662
				450	110	\$5,835
				600	111	\$6,009
				800	114	\$6,251
IMM 100 B	5.0	8.6	6.8	350	117	\$6,512
				450	119	\$6,675
				600	120	\$6,837
				800	123	\$7,101

Competitively priced replacement pumps for tool and cutting machines, as well as for the glass grinding and printing industries.
 High Pressure multi-stage pump designs are also available, please inquire.

SPV / IMM - FLOW PERFORMANCE

US Gallons per minute / Prevalence Head in Meters

Head in Meters

Part Number	HP	Gas Thread	Head in Meters															GALLONS PER MINUTE			
			0	1	2	3	4	5	6	7	8	9	10	11	12	13	14		15		
SPV 12	0.12	3/4"	15	12	9	6	2	-	-	-	-	-	-	-	-	-	-	-	-	-	
SPV 18	0.18	3/4"	17	15	13	10	6	1	-	-	-	-	-	-	-	-	-	-	-	-	-
SPV 25	0.25	3/4"	19	17	15	13	10	5	-	-	-	-	-	-	-	-	-	-	-	-	-
SPV 33	0.33	3/4"	21	19	17	14	11	7	1	-	-	-	-	-	-	-	-	-	-	-	-
SPV 50	0.50	1 1/4"	44	41	38	35	32	29	25	21	16	11	5	-	-	-	-	-	-	-	-
SPV 75	0.75	1 1/4"	60	57	54	51	48	44	40	36	32	27	22	16	7	-	-	-	-	-	-
SPV 100	1.00	1 1/4"	78	74	70	66	61	56	51	45	39	33	26	18	9	-	-	-	-	-	-
SPV 150	1.50	1 1/4"	95	91	86	81	76	70	64	58	51	44	35	24	15	-	-	-	-	-	-
IMM 71A	0.50	1"	63	61	58	54	52	44	45	41	38	34	29	23	18	10	1	-	-	-	-
IMM 71B	0.75	1"	63	61	58	55	53	50	47	44	40	37	33	25	18	16	15	8	-	-	-
IMM 80A	1.00	1 1/4"	77	74	71	68	64	61	58	56	52	47	41	36	31	25	19	11	-	-	-
IMM 80B	1.50	1 1/4"	103	100	97	94	91	88	84	80	76	73	69	64	59	54	49	43	-	-	-
IMM 90A	2.00	2"	245	230	216	201	187	166	146	118	90	61	31	-	-	-	-	-	-	-	-
IMM 90B	3.00	2"	339	326	313	300	286	272	258	239	220	200	180	154	128	87	45	-	-	-	-
IMM 100B	5.00	2 1/2"	378	365	353	339	325	310	295	555	261	242	224	206	188	161	135	108	-	-	-

STANDARD IMPELLER DIRECTION OF ROTATION IS CLOCK-WISE WHEN FACING THE FAN COVER.

SPV / IMM - Immersion Type Pumps (3-Phase)

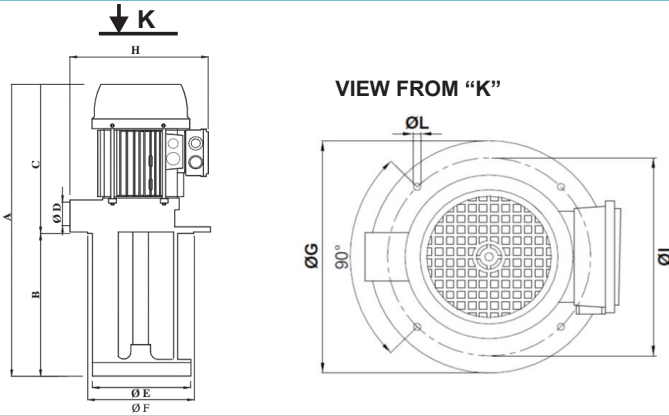

Part Number	HP	A	B	Weight (lbs)	C	D - Gas Thread	E	F	G	H	I	L	Mounting Holes
SPV 12 / SPV 18	0.12 / 0.18	255/285	90/120 T	6/7	165	3/4"	98	100	130	151	115	7	4
		335/385	170/220 T	7									
		435/515	270/350 T	7/8									
SPV 25 / SPV 33	0.25 / 0.33	300/330	90/120 T	10 / 11	210	3/4"	98	100	130	170	115	7	4
		380/430	170/220 T	10 / 11									
		480/560	270/350 T	11 / 12									
SPV 50 / SPV 75	0.50 / 0.75	460	200 T	17 / 20	260 (250*)	1 1/4"	138	140	180	215	160	9	4
		530	270 T	19 / 21									
		610	350 T	20 / 22									
		690*	440*	35 / 37									
		800*	550*	38 / 40									
SPV 100 / SPV 150	1.00 / 1.50	500	200 T	23 / 26	300	1 1/4"	138	140	180	230	160	9	4
		570	270 T	24 / 27									
		650	350	26 / 29									
		740*	440*	42 / 44									
		850*	550*	45 / 48									
IMM 90A / IMM 90B	2.00 / 3.00	695	350	105 / 109	345	2"	235	240	300	130	270	13	4
		795	450	107 / 110									
		945	600	108 / 111									
		1145	800	111 / 114									
IMM 100B	5.00	730	350	117	380	2 1/2"	235	240	300	145	270	13	4
		830	450	119									
		980	600	120									
		1180	800	123									

* Cast Iron T = TRI mode for glass processing machinery

SQ - Side Mount



View from "W" (Flange Details)

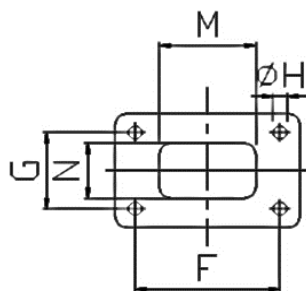

View from "K"

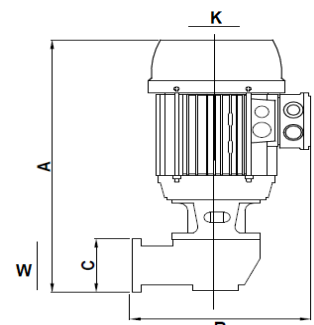
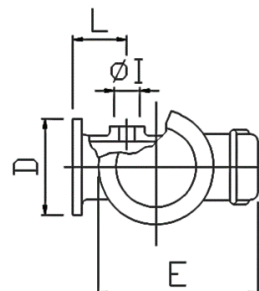

Type SQ - Side Mount

Part Number	Absorbed kW	HP	Weight (lbs)	US Gallons/Minute - Prevalence Head (m)					Dimensions (mm)								Price (\$)				
				0	1	2	3	4	A	B	C	D	E	F	G	H		I	L	M	N
SQ 56	0.16	0.18	9	15.9	12.7	9.2	7.1	2.9	265	170	60	95	140	75	45	7	3/8"	51	50	30	\$844
SQ 63	0.30	0.25	11	21.1	18.2	14.3	10.8	7.1	300	180	60	95	158	75	45	7	1/2"	51	50	30	\$1,269

Type AU - Self Priming

Dimensions

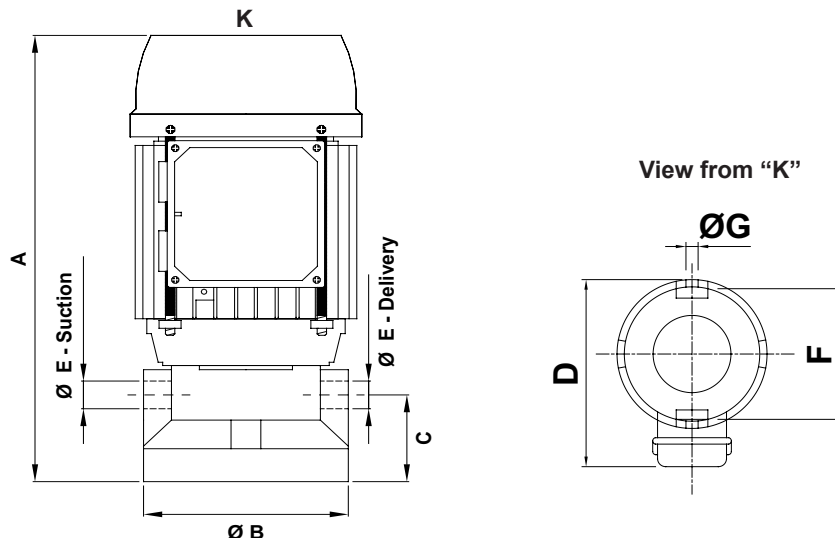

Part Number	Absorbed kW	HP	Weight (lbs)	US Gallons/Minute - Prevalence Head in Meters											Dimensions (mm)							Price (\$)		
				0	1	2	3	4	5	6	7	8	9	10	A	B	C	D	E	F	G			
AU 56	0.16	0.18	10	1.8	1.6	1.3	1.1	0.8	0.5	0.3							215	115	48	114	3/8"	95	7	\$1,053
AU 63	0.30	0.25	12	2.9	2.6	2.4	2.1	1.8	1.6	1.3	1.1	0.8	0.5	0.3			270	115	48	165	1/2"	95	7	\$1,566

AP - Immersion Pump

Overview



Available in frame sizes 80-122, up to 7.5 HP upon request.

Suitable for transferring liquids containing impurities up to 2 mm (closed impeller) or 3 mm (open impeller). Their hydraulic components: impeller and feed screw in cast iron, pump body in cast iron/ steel allow them to be used with water, emulsions and oily substances in general, with a viscosity not exceeding 21 cSt (3° Engel). The temperature of the liquid must not exceed 90°C. They are commonly used on:

- machine tools (milling and turning machines-machining centres)
- glass processing machinery
- surface treatment plants
- filtration systems

MP - Immersion Pump - Multistage High Pressure/Flow

Overview



Available in frame sizes 63-100, up to 5.5 HP upon request.

Suitable for transferring liquids containing impurities up to 3 mm in size. Their hydraulic components: impeller in brass and feed screw and pump body in aluminum allow them to be used with water, emulsions and oily substances in general, with a viscosity not exceeding 21 cSt (3° Engel). The temperature of the liquid must not exceed 90°C. They are commonly used on:

- machine tools (milling and turning machines-machining centres)
- glass processing machinery
- filtration systems

Featured SITI Gearboxes

Range

Right Angle Worm Gearboxes (Pages 40-51)

- Available with stainless steel output shaft
- Maximum input power of 55 kW
- Hollow, or solid output shaft in single or double design
- Single and double reduction available
- Ratios 5:1 to 100:1 (single stage reduction) and up to 10,000:1 (combination gearboxes)
- Various input sizes

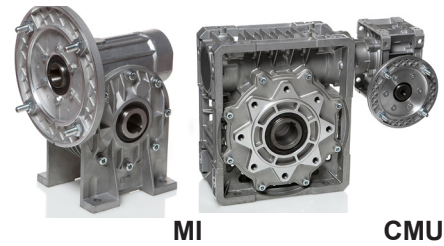

Inline Helical Gearboxes (Pages 53-56)

- Ratios up to 466:1
- Maximum torque 12,000 Nm
- Maximum input power of 336 kW
- Tough - strengthened by ribs for maximum performance
- IEC shaft & flange inputs/outputs
- Designed to fit standard IEC motors
- Base or various motor flange outputs
- 10 sizes with 3 input versions

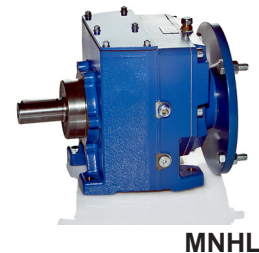

Bevel Helical Gearboxes (Page 52)

- Torque arms available
- Maximum input power of 337 kW
- 9 sizes that offer a wide range of mounting options
- Reduction ratios up to 226:1
- Output torque from 12 Nm to 14,000 Nm
- Hollow, single or double output shafts, shrink disk
- Extremely compact, modular & versatile

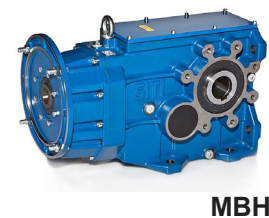

Shaft Mounted Helical Gearboxes (Inquire)

- 7 sizes that offer a wide range of possible mounting positions
- Maximum input power 108 kW
- High resistant gears with oversized bearings
- Superior sealing for leak prevention
- Maximum torque 6,876 Nm
- Ratio up to 30:1



Motovariators (Page 52)

- Zero speed option available
- IEC shaft & flange inputs/outputs
- Mechanical variable speed control
- Designed to fit standard IEC motors
- 7 sizes, 200+ versions, with a wide range of mounting positions
- Maximum input power of 11 kW
- Maximum torque of 3,000 Nm
- Planets & races are made in special steel 100Cr6



Planetary Gearboxes (Page 57)

- Direct, foot mount & flange mount options
- Modular design with compact sub grouping for simple ratio replacement (maximum of 4 reduction stages)
- 7 sizes available with 4 available input & output configurations
- Ratio range up to 4,066:1
- Maximum output torque of over 30,000 Nm
- Maximum input power of 45 kW
- Standard & high load output support connections



NEMA Inputs for OEM/High volume quantities may be available. Please contact a Lafert Sales Representative at 1-800-661-6413 for more information.

MI / MU - Right Angle Worm Gearboxes



MI - I Series Worm Gearboxes

MI - I Series Worm Gearboxes					ADDITIONAL FEATURES & ACCESSORIES (Add \$)							
Size	Oil	Weight (lbs)	MI Series Price \$	I Series Price \$ (Factory Option)	Base per Side	Output Flange (F or FBR)	Output Flange (FBM)	Single Output Shaft	Double Output Shaft	Torque Arm	Double Input Shaft	Torque Limiter
I 25 +	*	3	460.00	407.00	27.00	27.00	-	-	-	-	114.00	-
MI 30	*	5	527.00	457.00	-	54.00	-	97.00	107.00	-	132.00	-
MI 40	*	8	621.00	532.00	61.00	51.00	56.00	115.00	171.00	104.00	158.00	332.00
MI 50	*	10	798.00	691.00	67.00	60.00	67.00	181.00	199.00	135.00	201.00	415.00
MI 60	*	21	1116.00	923.00	83.00	78.00	87.00	199.00	245.00	187.00	253.00	645.00
MI 70	*	24	1149.00	1032.00	97.00	89.00	101.00	219.00	273.00	222.00	289.00	727.00
MI 80	*	38	1680.00	1510.00	119.00	295.00	325.00	255.00	304.00	283.00	422.00	925.00
MI 90	*	48	1822.00	1617.00	146.00	377.00	417.00	264.00	303.00	296.00	459.00	1101.00
MI 110	**	69	2542.00	2261.00	161.00	643.00	-	308.00	338.00	447.00	643.00	1414.00
MI 130	**	107	4148.00	3732.00	491.00	885.00	-	413.00	503.00	455.00	1047.00	-
MI 150	**	161	5780.00	5249.00	609.00	1159.00	-	530.00	693.00	-	1457.00	-
MI 175	**	248	8952.00	8287.00	932.00	2240.00	-	703.00	845.00	-	2255.00	-

+ Includes solid input shaft & input flange (only) * Prelubricated ** Oil available on request at extra cost

Ex ATEX Approved and Inox version/stainless steel available upon request

MI Performance Rating Tables: Page 42 & 43

MI Dimensions: Page 44 - 46

MI Mounting Positions: Page 47

MU - U Series Worm Gearboxes

MU - U Series Worm Gearboxes					ADDITIONAL FEATURES & ACCESSORIES (Add \$)				
Size	Oil	Weight (lbs)	MU Series Price \$	U Series Price \$ (Factory Option)	Output Flanges (F, FBR, FBM, FBML)	Single Output Shaft	Double Output Shaft	Torque Arm	Double Input Shaft
MU 40	*	6	684.00	589.00	56.00	126.00	188.00	115.00	174.00
MU 50	*	8	878.00	761.00	67.00	200.00	218.00	149.00	220.00
MU 63	*	12	1,264.00	1,135.00	87.00	218.00	268.00	204.00	308.00
MU 75	*	20	1,759.00	1,661.00	102.00	244.00	324.00	249.00	464.00
MU 90	*	30	2,002.00	1,777.00	317.00	289.00	337.00	274.00	505.00
MU 110	*	42	2,797.00	2,487.00	417.00	339.00	374.00	324.00	704.00

MU Performance Rating Tables: Page 48 & 49

MU Dimensions: Page 50

MU Mounting Positions: Page 49

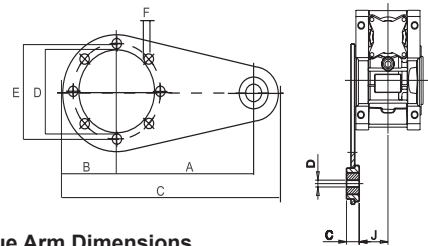

Ex ATEX Approved Gearboxes - add 20% Inox version/stainless steel - add 40%

MU - Output Shaft Dimensions

Size	A	A ₁	B	C	B ₁	C ₁	Dh ₇	d	L	b ₁	t ₁
U-MU 40	39	78	43	43	40	40	18	M5	164	6	20.5
U-MU 50	46	92	53.5	53.5	50	50	25	M8	199	8	28
U-MU 63	56	112	65	53.5	60	50	25	M8	219	8	28
U-MU 75	60	120	70	63.5	60	60	28	M8	247	8	31
U-MU 90	70	140	65	84.5	60	80	35	M8	309	8	38
U-MU 110	77.5	155	126	84.5	110	80	42	M10	324	12	45

MI / MU - Torque Arm Dimensions

Size	A	B	C	D	E	F	G	H	I	J
40	100	40	170	50	65	7	20	10	4	29.5
50	100	44	180	60	75	7	20	10	4	35.5
60 / 63	150	53	233	70	85	9	20	10	6	46
70 / 75	200	62.5	300	80	100	9	25	14	6	47.5
80	200	77.5	315	110	130	11	25	14	6	-
90	200	77.5	315	110	130	11	25	14	6	57.5
110	250	100	387.5	130	165	13	25	14	6	64.5
130	300	120	465	180	215	13	30	16	8	-
150	300	125	470	180	215	15	30	16	8	-

MI - Output Shaft Dimensions

Size	A	A ₁	B	C	Dh ₇	d	L	b ₁	t ₁
I-MI 30	28.5	57	35	30	14	M5	127	5	16
I-MI 40	41	82	50	40	19	M8	182	6	21.5
I-MI 50	49	98	60	50	24	M8	218	8	27
I-MI 60	60	120	65	60	25	M8	250	8	28
I-MI 70	60.5	121	70	60	28	M8	261	8	31
I-MI 80	70	140	65	60	35	M8	270	10	38
I-MI 90	75	150	96	80	38	M8	342	10	41
I-MI 110	77.5	155	126	110	42	M10	407	12	45
I-MI 130	95	190	126	110	48	M10	442	14	51.5
I-MI 150	110	220	132	110	55	M12	484	16	59
I-MI 175	115	230	150	140	60	M12	530	18	64

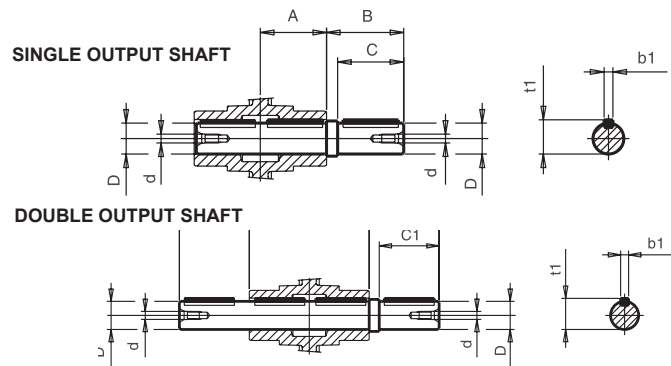

Service Factors

The following table provides the service factors relating to the most common applications in which Right Angle Worm Gearboxes are utilized. For applications that do not appear in the table, the relative value may be selected by taking into account the following characteristics:

- Applied Load, Number of Working Hours per Day, and Number of Start/Stops per hour.

When brake motors are used, the values in the service factor table must be multiplied by 1.12.

Load Classification	Application	Starts/hr.	Average Operating Hours Per Day			
			<2	2 to 8	9 to 16	17 to 24
Easy load starting, smooth operation, small load acceleration.	Centrifugal Pumps - Bottling Equipment - Belt Conveyors with uniform loads - Low Shock Load Applications - Can Filling Machines - Sewage Clarifier's	< 10	0.75	1	1.25	1.5
Moderate load starting, uneven operating conditions, medium load accelerations.	Shakers & Mixers - Kneading Drums - Screw Conveyors - Textile Machinery - Belt Conveyors (uneven load distribution) - Heat Treatment Ovens - Bucket Elevators - Wire Drawing Machines - Meat Grinders.	<10	1	1.25	1.5	1.75
		10 to 50	1.25	1.5	1.75	2
		50 to 100	1.5	1.75	2	2.2
		100 to 200	1.5	1.75	2	2.2
Heavy load starting, uneven loads, heavy load accelerations.	Deburring Drums, Milling Machines, Lifting Winches, Conveyor with Shock Loading, Concrete Mixers, Shear Pressers, Rotary Kilns, Punch Presses, Aggregate Conveyors - Heavy Duty Hoists - Recycling Machinery	<10	1.25	1.5	1.5	2
		10 to 50	1.5	1.75	1.75	2.2
		50 to 100	1.75	2	2	2.5
		100 to 200	2	2.2	2.2	3

I 80 I175

PAM (Quill Input)

PARTS DESCRIPTION

1. Oil Seal
2. Foot
3. Gasket
4. Bearing
5. Cover
6. Bearing
7. Cover
8. Crown Gear
9. Body
10. Key
11. Oil Seal
12. Screw
13. Screw
14. Worm Screw
15. Flange
16. Gasket
17. Nut
18. Flange
19. Screw
20. Screw
21. Worm Screw Pam

MOTOR SHAFT & FLANGE DIAMETERS Pre-Arranged for Motor Mounting (PAM)

Input Flange Type	Frame										
	56	63	71	80	90	100	112	132	160	180	200
B5	9/120	11/140	14/160	19/200	24/200	28/250	28/250	38/300	42/350*	48/350*	55/400*
B14	9/80	11/90	14/105	19/120	24/140	28/160	28/160	38/200**	-	-	-

* MI series only

** MU series only

Ratings Table (Sizes 25-50)

1.0 Service Factor

Ratio	n1	n2	I-MI-25				I-MI-30				I-MI-40				I-MI-50			
			M2	kW	HP	RD	M2	kW	HP	RD	M2	kW	HP	RD	M2	kW	HP	RD
7.5	3360	448	7	0.40	0.54	85%	13	0.69	0.93	86%	22	1.15	1.57	88%	41	2.16	2.93	88%
	1680	224	8	0.24	0.32	83%	15	0.42	0.56	84%	26	0.71	0.97	86%	49	1.34	1.83	86%
	1080	144	10	0.18	0.24	81%	17	0.31	0.43	82%	30	0.55	0.74	84%	58	1.04	1.41	84%
	800	107	12	0.11	0.15	79%	22	0.19	0.26	80%	38	0.32	0.44	82%	72	0.61	0.83	82%
10	3360	336	7	0.31	0.42	82%	14	0.57	0.77	84%	23	0.91	1.24	87%	44	1.80	2.45	86%
	1680	168	8	0.18	0.25	80%	17	0.36	0.49	82%	27	0.56	0.76	85%	54	1.13	1.54	84%
	1080	108	10	0.14	0.19	78%	20	0.28	0.38	80%	31	0.43	0.58	83%	64	0.88	1.19	82%
	800	80	12	0.08	0.11	76%	24	0.16	0.22	78%	39	0.25	0.33	81%	78	0.51	0.70	80%
15	3360	224	7	0.22	0.29	78%	14	0.40	0.54	79%	24	0.69	0.93	83%	50	1.42	1.92	82%
	1680	112	8	0.13	0.18	76%	17	0.25	0.35	77%	30	0.43	0.59	81%	60	0.89	1.20	80%
	1080	72	10	0.10	0.13	74%	20	0.20	0.27	75%	35	0.34	0.46	79%	71	0.69	0.94	78%
	800	53	12	0.06	0.08	72%	24	0.12	0.16	73%	43	0.20	0.27	77%	88	0.40	0.55	76%
20	3360	168	7	0.16	0.22	77%	14	0.33	0.44	73%	29	0.63	0.86	80%	44	0.97	1.32	80%
	1680	84	8	0.10	0.13	75%	17	0.20	0.28	72%	35	0.40	0.54	78%	54	0.61	0.83	78%
	1080	54	10	0.07	0.10	74%	20	0.16	0.22	71%	42	0.31	0.42	76%	64	0.47	0.64	76%
	800	40	12	0.04	0.06	71%	24	0.09	0.13	68%	51	0.18	0.25	74%	78	0.28	0.38	74%
25	3360	134	8	0.17	0.22	69%	15	0.28	0.38	77%	19	0.34	0.46	78%	43	0.79	1.07	77%
	1680	67	9	0.10	0.13	68%	19	0.17	0.24	75%	33	0.31	0.42	76%	53	0.50	0.68	75%
	1080	43	11	0.08	0.10	67%	22	0.13	0.18	74%	39	0.24	0.32	74%	63	0.38	0.52	74%
	800	32	12	0.04	0.06	65%	27	0.08	0.11	71%	49	0.14	0.19	72%	77	0.23	0.31	71%
30	3360	112	9	0.16	0.22	65%	17	0.30	0.41	66%	32	0.52	0.71	71%	56	0.91	1.24	72%
	1680	56	11	0.10	0.14	64%	20	0.18	0.25	65%	38	0.32	0.43	70%	68	0.56	0.76	71%
	1080	36	13	0.08	0.11	63%	24	0.14	0.19	64%	45	0.24	0.33	69%	80	0.43	0.58	70%
	800	27	15	0.05	0.06	61%	30	0.08	0.11	62%	55	0.15	0.20	67%	99	0.25	0.35	67%
40	3360	84	8	0.11	0.15	63%	15	0.20	0.27	68%	31	0.41	0.56	65%	49	0.69	0.94	62%
	1680	42	10	0.07	0.10	62%	19	0.12	0.17	67%	37	0.26	0.35	64%	60	0.43	0.58	61%
	1080	27	12	0.06	0.08	61%	22	0.09	0.13	66%	44	0.20	0.27	63%	70	0.33	0.45	60%
	800	20	14	0.03	0.04	59%	27	0.06	0.08	64%	54	0.12	0.16	61%	86	0.20	0.27	58%
50	3360	67	8	0.11	0.14	54%	14	0.16	0.22	64%	31	0.34	0.46	63%	48	0.54	0.74	62%
	1680	34	9	0.06	0.08	53%	18	0.10	0.13	63%	37	0.21	0.29	62%	58	0.33	0.45	61%
	1080	22	11	0.05	0.07	52%	21	0.08	0.10	62%	44	0.16	0.22	61%	67	0.25	0.35	60%
	800	16	13	0.03	0.04	50%	26	0.04	0.06	60%	54	0.10	0.13	59%	84	0.15	0.21	58%
60	3360	56	7	0.08	0.11	52%	13	0.15	0.20	50%	29	0.28	0.38	60%	44	0.46	0.63	56%
	1680	28	8	0.05	0.07	51%	16	0.09	0.13	49%	35	0.18	0.24	59%	54	0.29	0.39	55%
	1080	18	10	0.04	0.05	50%	19	0.07	0.10	48%	42	0.14	0.18	58%	64	0.22	0.30	54%
	800	13	12	0.02	0.03	48%	23	0.04	0.06	47%	51	0.08	0.11	56%	78	0.13	0.18	52%
80	3360	42	5	0.04	0.06	48%	9	0.07	0.10	56%	23	0.20	0.27	51%	43	0.35	0.47	55%
	1680	21	6	0.03	0.04	47%	11	0.04	0.06	55%	28	0.12	0.17	50%	52	0.21	0.29	54%
	1080	14	7	0.02	0.03	46%	13	0.03	0.05	54%	33	0.10	0.13	49%	61	0.16	0.22	53%
	800	10	8	0.01	0.02	45%	16	0.02	0.03	52%	41	0.06	0.08	48%	76	0.10	0.13	51%
100	3360	34	3	0.02	0.03	42%	5	0.04	0.05	48%	22	0.16	0.21	49%	40	0.28	0.39	49%
	1680	17	4	0.02	0.02	41%	7	0.02	0.03	47%	26	0.10	0.13	48%	48	0.18	0.24	48%
	1080	11	5	0.01	0.02	40%	8	0.02	0.03	46%	30	0.07	0.10	47%	57	0.14	0.19	47%
	800	8	5	0.01	0.01	39%	9	0.01	0.02	45%	38	0.04	0.06	46%	70	0.08	0.11	46%

n1 = Input Speed
n2 = Output Speed

M2 = Output Torque (Nm)
kW = Input kW

HP = Input HP
RD = Dynamic Efficiency

Use factor 8.85 to convert Nm to in lbs.



I-MI - Right Angle Worm Gearboxes

Dimensions (Size 30)

MI 30

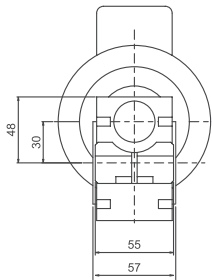

I 30

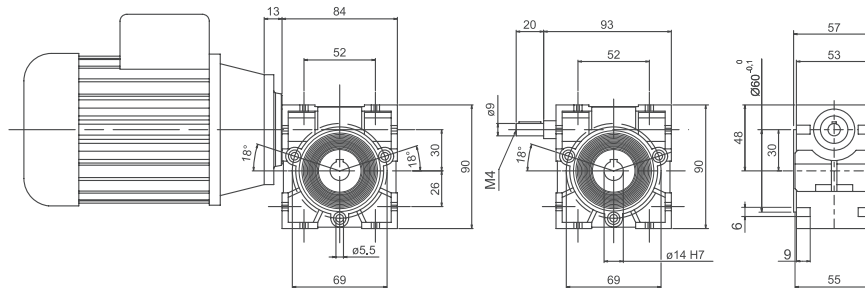

MI 30 F

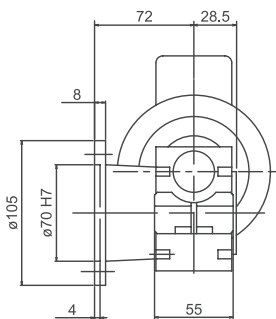

I 30 F

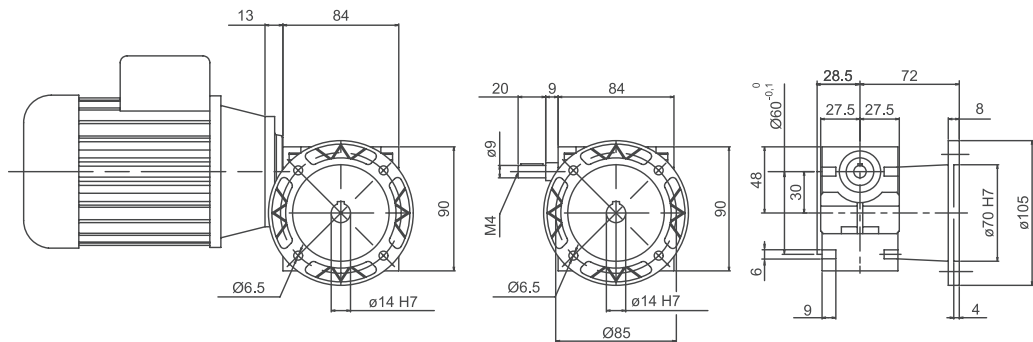

MI 30 FBC

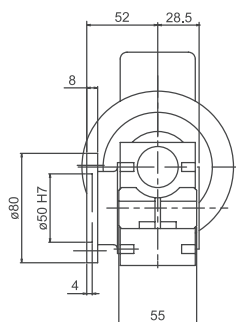

I 30 FBC

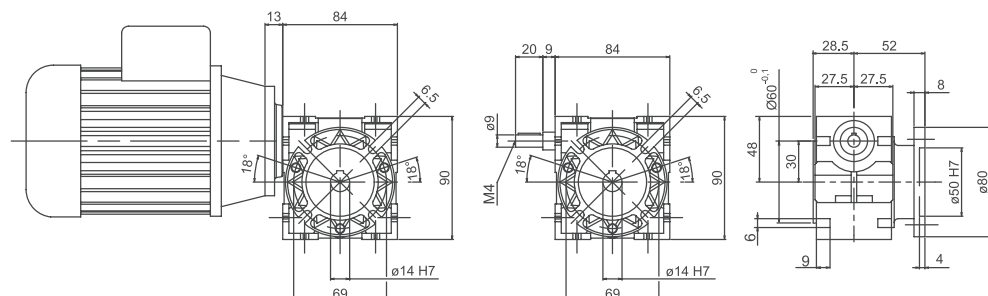

Dimensions (Sizes 40-70)

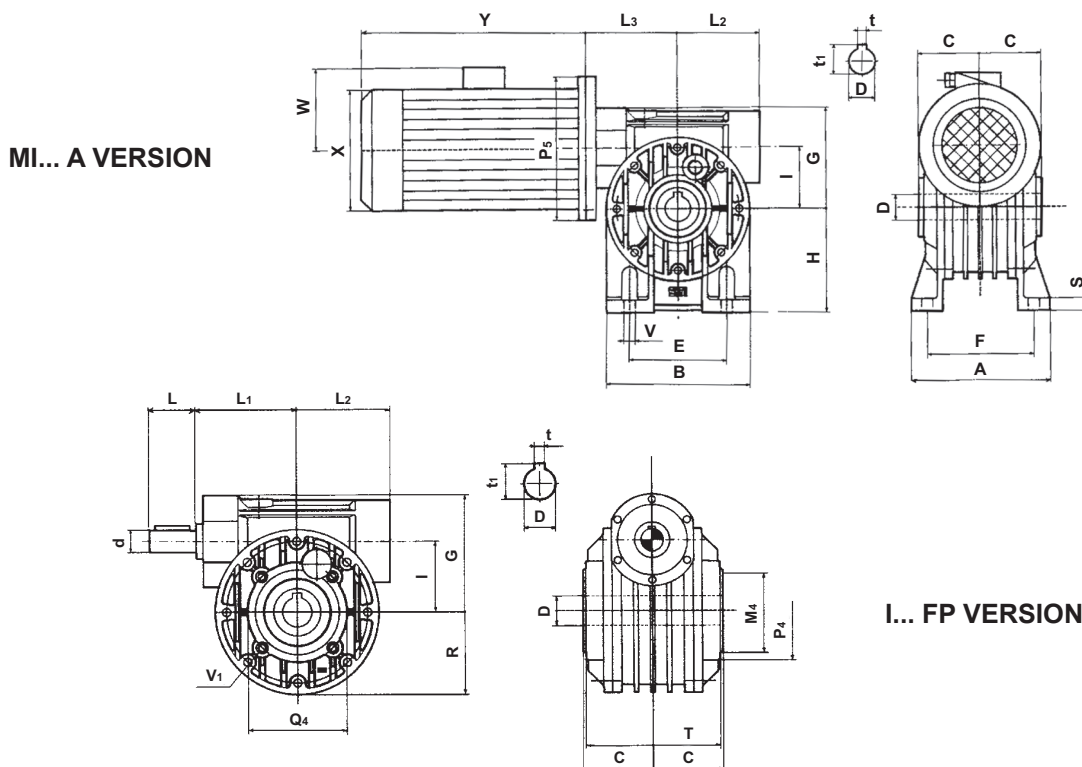

Right Angle Worm Base Mount or Round Body

x, y, w standard motor dimensions

Frame Size	L ₃	L ₂	G	R	A	B	E	F	V	H	H ₁	H ₂	C	S	D/H ₇	t	t ₁	P ₅	d/j ₆	L	L ₁	I	T	Q ₄	P ₄	M ₄ /H ₇	V ₁
40	71	57	70	48	100	96	70	84	7	71	111	31	41	8	19(18)	6	21.8	*	11	23	63	40	77	65	96	50	M6
50	82	64	84	56	114	112	85	96	9	85	135	35	49	10	24(25)	8	27.3	*	14	30	73	50	93	75	88	60	M6
60	101	80	99	75	137	140	95	111	11	100	160	40	60	12	25	8	28.3	*	19	40	86	60	104	85	105	70	M8
70	108	86	117	81	141	156	120	115	11	115	185	45	60.5	12	28	8	31.3	*	19	40	87	70	114	100	115	80	M8

() Optional output bore size

* According to IEC flange

I... F VERSION

I...FBM VERSION

I... FBR VERSION

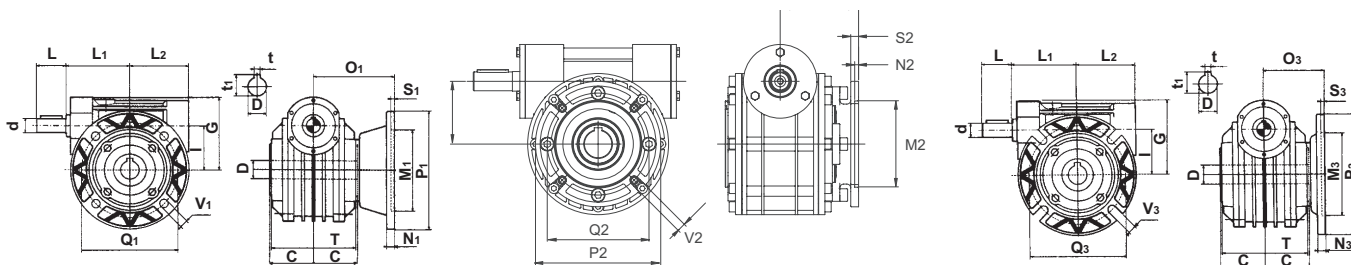

Right Angle Worm Base Mount with Solid Input Shaft & Output Flanges

Frame Size	L	L ₁	L ₂	C	T	G	d/j ₆	D/H ₇	Q ₁	Q ₂	Q ₃	M ₁ /H ₇	M ₂ /H ₇	M ₃ /H ₇	P ₁	P ₂	P ₃	O ₁	O ₂	O ₃	S ₁	S ₂	S ₃	V ₁	V ₂	V ₃	N ₁	N ₂	N ₃	t	t ₁
MI 40	23	63	57	41	77	70	11	19(18)	115	76-87	100	95	60	80	140	95	120	82	69	60	4	3	3	9	9	9	11	8	8	6	21.8
MI 50	30	73	67	49	93	84	14	24(25)	130	85-92	115	110	70	95	160	110	140	92	93	75	4	4	4	10	10	10	11	10	10	8	27.3
MI 60	40	86	80	60	104	99	19	25	165	150	130	130	115	110	200	142/180	160	96.5	81	76	4	4	5	11	11	10	12	11	11	8	28.3
MI 70	40	87	86	60.5	114	117	19	28	165	130	130	130	110	110	200	200/210	160	111.5	85	85	5	4	5	13	11	11	12	12	12	8	31.3

() Optional output bore size

Dimensions (Sizes 80-175)

MI... A VERSION

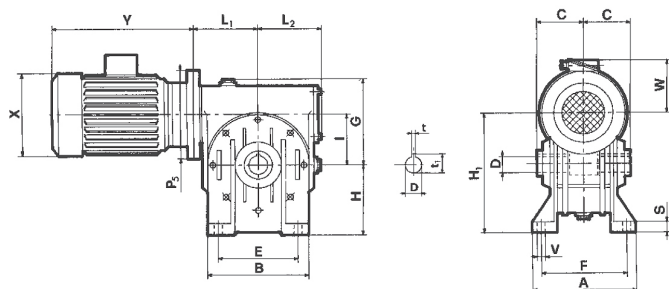

I... FBR VERSION

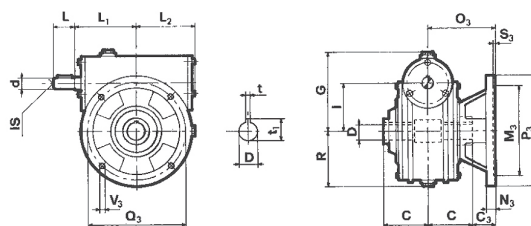

I... FP VERSION

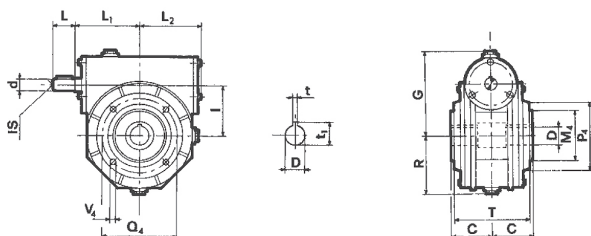

I... F VERSION

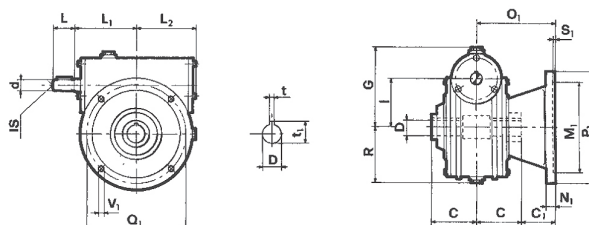

x, y, w standard motor dimensions

Frame Size	A	B	C	D/H ₇	E	F	S	V	G	H	H ₁	H ₂	I	L ₃	L ₂	R	t	t ₁	P ₅	C ₁	C ₂	C ₃
MI 80	181	180	70	35	140	147	13	11	127	142	222	62	80	108	105	95	10	38.3	*	50	80	30
MI 90	198	210	75	38	160	164	15	13	139	150	240	60	90	128	124	111	10	41.3	*	52	75	40
MI 110	190	250	77.5	42	200	160	18	13	170	172	282	62	110	149	144	141	12	45.3	*	72.5	100.5	52.5
MI 130	225	280	95	48	240	190	18	15	194	200	330	70	130	165	160	155	14	51.8	*	55	102.5	42.5
MI 150	260	334	110	55	280	220	20	19	225	230	380	80	150	192	190	182	16	60.3	*	65	110	-
MI 175	280	358	115	60	310	240	30	19	258	260	435	85	175	213	204	203	18	64.4	*	95	140	-

* According to IEC flange

Refer to dimensions Q2, P2 and M2 for FR Output Flange

Frame Size	M ₁ /H ₇	M ₂ /H ₇	M ₃ /H ₇	M ₄ /H ₇	N ₁	N ₂	N ₃	O ₁	O ₂	O ₃	P ₁	P ₂	P ₃	P ₄	Q ₁	Q ₂	Q ₃	Q ₄	S ₁	S ₂	S ₃	V ₁	V ₂	V ₃	V ₄	d/J ₆	IS	L	L ₁	T
MI 80	130	152	110	110	13	13	13	120	150	100	200	200/210	160	145	165	180	130	130	5	6	5	11.5	11.5	11.5	M10	24	M8	50	110	133
MI 90	180	152	130	110	14	15	15	127	150	115	250	250	200	160	215	180	165	130	5	5	5	14	11	11	M10	24	M8	50	126	143
MI 110	180	170	180	130	18	18	18	150	178	130	250	300	250	200	215	230	215	165	5	5	5	15	12.5	15	M12	28	M8	60	148	148
MI 130	230	180	230	180	18	20	18	150	198	137.5	300	300	300	240	265	255	265	215	5	6	5	15	12.5	15	M12	38	M10	80	167	172
MI 150	250	200	*	180	20	22	*	175	220	*	350	350	*	250	300	280	*	215	6	6	*	17	12.5	*	M14	42	M12	110	193	204
MI 175	300	280	*	230	22	22	*	210	255	*	400	400	*	300	350	350	*	265	6	6	*	18	12.5	*	M16	42	M12	110	210	222

* According to IEC flange

Mounting Positions

Version	B3	V5	B8	V6	B6	B7
A						
B						
C						

Version	B5	B51	B53	B52	V1	V3
F FBR FBM FBML						
FP						

○ Fill-in plug

◐ Oil level plug

● Drain plug

Ratings Table (Sizes 90-110) & Mounting Positions

1.0 Service Factor

Ratio	n1	n2	U-MU-90				U-MU-110			
			M2	kW	HP	RD	M2	kW	HP	RD
5	3360	672	-	-	-	-	-	-	-	-
	1680	336	-	-	-	-	-	-	-	-
	1080	216	-	-	-	-	-	-	-	-
	800	160	-	-	-	-	-	-	-	-
7.5	3360	448	240	12.28	16.69	92%	372	19.14	26.02	91%
	1680	224	344	8.89	12.08	91%	536	13.90	18.89	90%
	1080	144	390	6.55	8.91	90%	599	10.15	13.80	89%
	800	107	470	3.87	5.26	85%	727	5.90	8.03	86%
10	3360	336	243	9.42	12.80	91%	401	15.54	21.12	91%
	1680	168	343	6.76	9.19	89%	569	11.24	15.27	89%
	1080	108	385	4.96	6.74	88%	640	8.20	11.15	88%
	800	80	456	2.91	3.96	82%	759	4.72	6.42	84%
15	3360	224	248	6.74	9.17	86%	435	11.63	15.80	88%
	1680	112	348	4.72	6.42	86%	605	8.21	11.17	86%
	1080	72	399	3.57	4.86	84%	669	5.91	8.03	85%
	800	53	490	2.19	2.98	78%	794	3.45	4.69	80%
20	3360	168	297	6.10	8.30	86%	489	9.90	13.46	87%
	1680	84	397	4.12	5.61	85%	662	6.84	9.29	85%
	1080	54	428	2.97	4.04	81%	731	4.96	6.75	83%
	800	40	520	1.76	2.40	77%	863	2.91	3.96	78%
25	3360	134	259	4.28	5.81	85%	436	7.07	9.61	87%
	1680	67	347	2.96	4.02	83%	583	4.87	6.62	84%
	1080	43	336	1.92	2.61	79%	646	3.59	4.89	81%
	800	32	451	1.28	1.74	74%	761	2.12	2.89	75%
30	3360	112	338	4.83	6.65	82%	491	6.92	9.40	83%
	1680	56	453	3.38	4.59	79%	653	4.83	6.57	80%
	1080	36	494	2.47	3.36	75%	732	3.62	4.92	76%
	800	27	588	1.45	1.97	71%	865	2.14	2.91	71%
40	3360	84	314	3.53	4.80	78%	510	5.46	7.42	82%
	1680	42	425	2.49	3.38	75%	687	3.87	5.26	78%
	1080	27	466	1.85	2.51	71%	759	2.89	3.93	74%
	800	20	542	1.08	1.47	66%	885	1.75	2.38	66%
50	3360	67	275	2.54	3.45	76%	587	5.24	7.12	79%
	1680	34	363	1.76	2.39	73%	611	2.86	3.89	75%
	1080	22	404	1.34	1.82	68%	660	2.10	2.86	71%
	800	16	458	0.79	1.07	61%	771	1.29	1.76	62%
60	3360	56	262	2.13	2.90	72%	440	3.33	4.53	77%
	1680	28	341	1.45	1.97	69%	575	2.34	3.18	72%
	1080	18	375	1.10	1.50	64%	630	1.74	2.36	68%
	800	13	427	0.65	0.89	57%	712	1.05	1.43	59%
70	3360	48	248	1.80	2.44	70%	421	2.95	4.01	72%
	1680	24	324	1.27	1.73	64%	551	1.98	2.69	70%
	1080	15	351	0.96	1.30	59%	598	1.53	2.07	63%
	800	11	402	0.56	0.76	54%	684	0.91	1.24	56%
80	3360	42	229	1.45	1.97	69%	398	2.40	3.26	73%
	1680	21	297	1.03	1.40	63%	513	1.69	2.29	67%
	1080	14	323	0.77	1.05	59%	556	1.24	1.69	63%
	800	10	367	0.48	0.65	50%	641	0.79	1.07	53%
100	3360	34	192	1.04	1.41	65%	356	1.82	2.47	69%
	1680	17	269	0.79	1.08	60%	465	1.29	1.76	63%
	1080	11	290	0.60	0.82	55%	601	1.17	1.59	58%
	800	8	355	0.41	0.56	45%	573	0.62	0.84	49%

n1 = Input Speed
n2 = Output Speed

M2 = Output Torque (Nm)
kW = Input kW

HP = Input HP
RD = Dynamic Efficiency

Use factor 8.85 to convert Nm to in lbs.

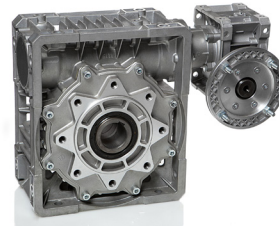

MOUNTING POSITIONS

Always recognize the required mounting position for the gearbox. Certain orientations require special lubricants and/or bearings to achieve the normal service life of the gearbox.

Unless specified, the gearbox will be shipped in a B3 position.

Note: Sizes 40 and 50 are suitable to be mounted in all positions.

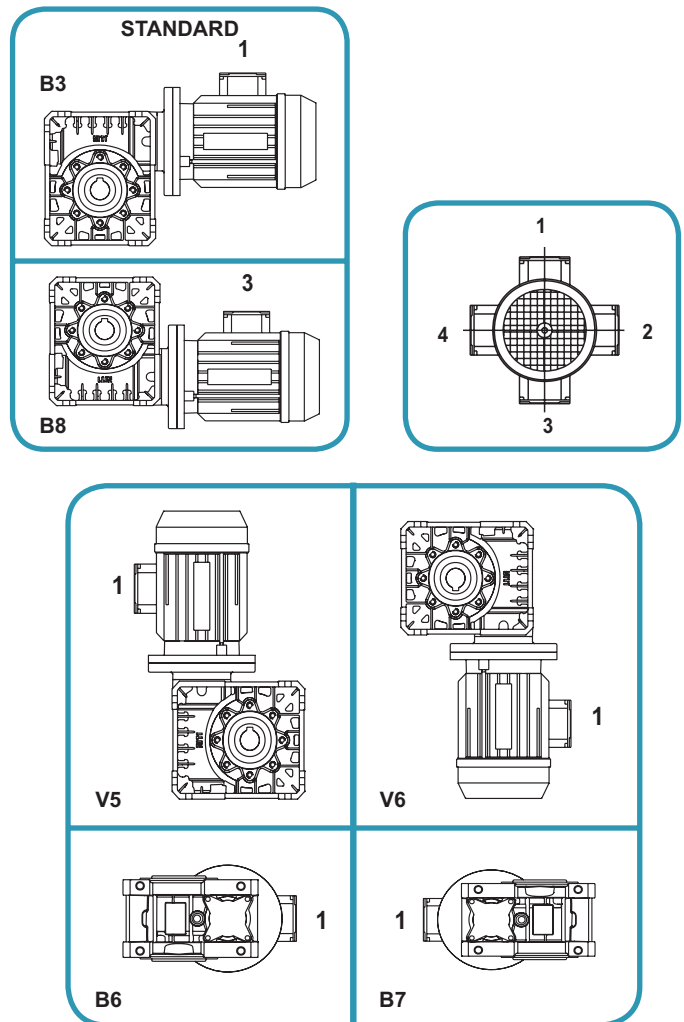

U-MU - Right Angle Worm Gearboxes



Dimensions

BASE MOUNT VERSION

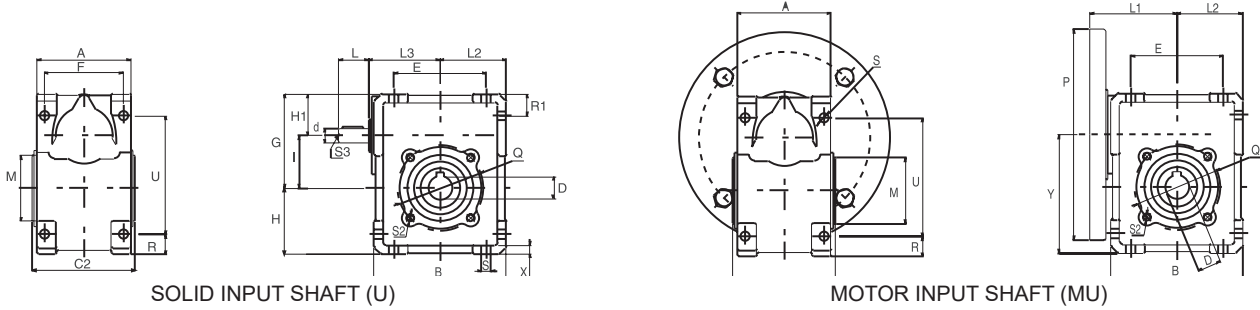

Size	I	DH7	t	t1	dJ6	S3	L	L3	L2	E	F	U	A	B	Y	H	H1	G	C2	R	M g6	Q	S	S2	X	R1	P	L1
40	40	18(19)	6	20.8	11	M4	23	54	50	70	60	90	71	100	90	50	31.5	71.5	78	15	50	65	7	M6	6.5	16.5	**	**
50	50	25(24)	8	28.3	14	M5	30	64	60	80	70	104	85	120	110	60	34	84	92	20	60	75	9	M6	7	20	**	**
63	63	25(28)	8	28.3	19	M6	40	76	72	100	85	130	102	144	135	72	39	102	112	22	70	85	9	M8	7	22	**	**
75	75	28(35)	8	31.3	24	M8	50	90	86	120	90	153	112	172	161	86	44	119	120	26	80	100	11	M8	10	26	**	**
90	90	35(38)	10	38.3	24	M8	50	107	103	140	100	172	130	206	193	103	45	135	140	33	110	130	13	M10	11	33	**	**
110	110	42	12	45.3	28	M10	60	131.5	127.5	170	115	210	144	252.5	237.5	127.5	57.5	167.5	155	42.5	130	165	14	M12	14	42.5	**	**

() Optional output bore size

** Inquire for P & L1 dimensions

MU... FBR VERSION

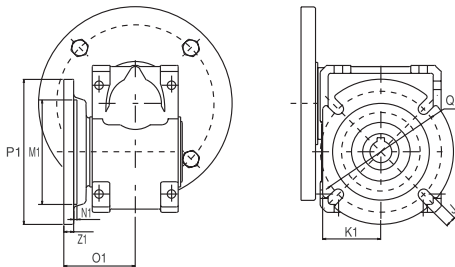

MU... FBML VERSION

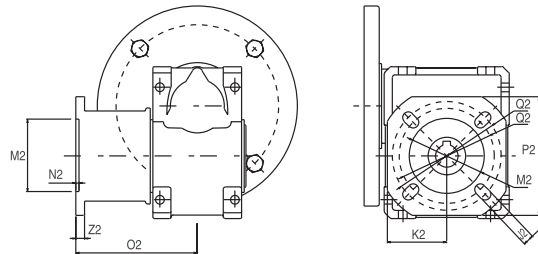

MU... F VERSION

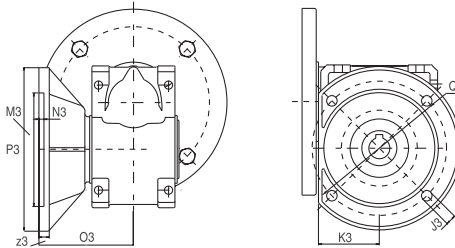

MU... FBM VERSION

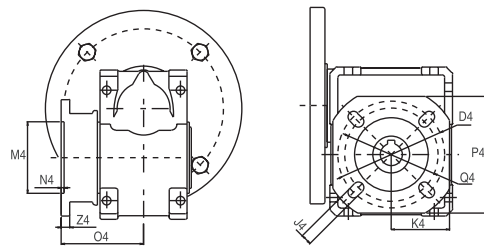

Size	FBR OUTPUT FLANGE								FBML OUTPUT FLANGE								F OUTPUT FLANGE								FBM OUTPUT FLANGE							
	Q1	M1H7	P1	K1	N1	Z1	O1	J1	Q2*	M2H7	P2	K2	N2	Z2	O2	J2	Q3	M3H7	P3	K3	N3	Z3	O3	J3	Q4*	M4H7	P4	K4	N4	Z4	O4	J4
40	100	80	120	48	3	8	59	9	76-87	60	95	47.5	4	7	97	9	115	95	140	52	4	9	81	9	76-87	60	95	47.5	4	7	67	9
50	115	95	140	58	4	10	72	10	85-92	70	110	55	5	10	120	11	130	110	160	61	4	10	89	10.5	85-92	70	110	55	5	10	90	11
63	130	110	160	70	5	11	77.35	11	138-150	115	142	71	6	11	112	11	165	130	200	74	4	12	97.3	11	138-150	115	142	71	6	11	82	11
75	-	-	-	-	-	-	-	-	165-188	130	200	85	5	12	111.3	14	-	-	-	-	-	-	-	-	130-140	110	160	80	5	12	84.8	11
90	-	-	-	-	-	-	-	-	-	-	-	-	-	-	-	-	-	-	-	-	-	-	-	-	175-210	152	200	100	6	13	111	14
110	-	-	-	-	-	-	-	-	-	-	-	-	-	-	-	-	-	-	-	-	-	-	-	-	230-280	170	260	130	6	15	131	14

Pre-Stage Reducers and Bushings

P (Pre-stage Reducers)

Available ratios: 3.1/1 & 4.1/1

Size	Oil	Weight (lbs)
P 63	**	3
P 71	**	5
P 80	**	11
P 90	**	16

** Oil included only when supplied with motor, at extra cost.

High Modularity

Helical worm gearboxes suitable for modular assembly of flanges, feet and torque arms.

High Versatility

It is possible to supply a separate kit for easy assembly on a standard gearbox.

High Reliability

Housing built in pressure die casting aluminum.

"ZI" teeth profile on worm and wormwheels for silent operation without vibration.

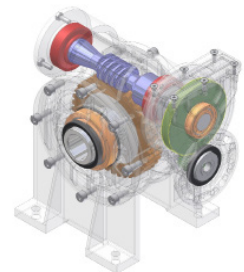
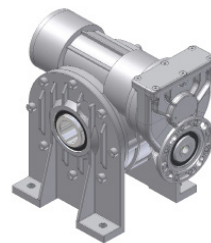
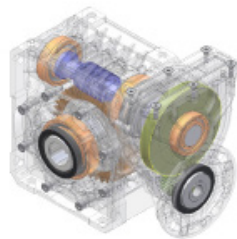
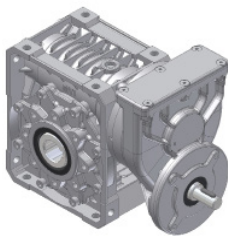

P + MU

Max input power 3.4 kW
 Max torque 1053Nm
 Ratios up to 404/1

P + MU	Max Torque Nm
P63 - MU40	78
P63 - MU50	130
P63/P71 - MU63	250
P71 - MU75	341
P71/P80 - MU90	639
P80/P90 - MU110	1053

P + MI

Max input power 7.5 kW
 Max torque 2500 Nm
 Ratios up to 404/1

P + MI	Max Torque Nm
P63 - MI40	78
P63 - MI50	130
P63/P71 - MI60	236
P63/P71 - MI70	286
P71/P80 - MI80	520
P80 - MI90	639
P80/P90 - MI110	1053
P90/P110 - MI130	1728
P110 - MI150	2511

Input Shaft Bushings

Steel Bushings
38mm to 28mm
28mm to 24mm
24mm to 19mm
19mm to 14mm
14mm to 11mm
11mm to 9mm



(M)BH - Bevel Helical Gearboxes



Product Information & Pricing

- Maximum Input Power of 337 kW
- Reduction Ratios from 10:1 to 226:1
- Universal Mounting Options
- Hollow, Single or Double Output Shafts



Size	Input Flange Size	Weight (lbs)	*MBH with B5 Input Price \$	*BH Price \$	ADDITIONAL FEATURES & ACCESSORIES (\$)					
					Output Flange	Torque Arm	Oil	Double Output Shaft	OP Shaft Taper Roller Bearing	Backstop
MBH56	63-71-80-90	36	2,153.00	2,197.00	195.00	139.00	96.00	N/A	146.00	N/A
MBH63	71-80-90	66	2,726.00	2,726.00	276.00	151.00	163.00	242.00	208.00	N/A
MBH63	100-112		2,965.00							
MBH80	71-80-90	88	4,351.00	4,317.00	317.00	249.00	287.00	278.00	370.00	N/A
MBH80	100-112		4,564.00							
MBH80	132		4,564.00							
MBH100	80-90	159	5,783.00	5,660.00	447.00	340.00	468.00	401.00	477.00	679.00
MBH100	100-112		5,961.00							
MBH100	132		6,259.00							
MBH125	80-90	214	7,571.00	7,418.00	696.00	494.00	652.00	464.00	568.00	1,019.00
MBH125	100-112		7,720.00							
MBH125	132		8,018.00							
MBH140	100-112	452	11,804.00	11,444.00	835.00	1,175.00	1,044.00	525.00	N/A	1,113.00
MBH140	132		13,144.00							
MBH160	100-112	573	15,797.00	15,380.00	948.00	1,175.00	1,668.00	556.00	N/A	1,452.00
MBH160	132		16,988.00							

* MBH Pricing includes one of the following:

- 1) Hollow Output Bore 2) Hollow Output Bore with Pre-arranged Tapered Lock Device 3) Single Solid Shaft

MKF - Motovariator (Speed Variator) Gearboxes

- (MK - MKF : K - KF) • Mechanical Speed Variator
- 228 to 1,200 RPM Range on 4 Pole, 60 Hz Motors • Maximum Input Power of 11 kW

Size	Weight (lbs)	PAM Flange MK Price \$	Male Input "K" Shaft Price \$	Zero Speed Option Price \$
MK2	20	1,327.00	1,457.00	N/A
MKF2	20	1,386.00	1,503.00	N/A
MK5	40	1,646.00	1,878.00	1,283.00
MKF5	40	1,743.00	1,934.00	1,283.00
MK10	66	2,104.00	2,394.00	1,464.00
MKF10	66	2,152.00	2,458.00	1,464.00
MK20	85	2,984.00	3,306.00	1,971.00
MKF20	85	3,059.00	2,790.00	1,629.00
MK30	120	4,380.00	4,815.00	2,611.00
MKF30	120	4,535.00	4,934.00	2,611.00
MK50	225	4,787.00	5,329.00	2,611.00
MKF50	225	4,916.00	5,353.00	2,611.00
MK100	355	7,616.00	8,616.00	5,198.00
MKF100	355	7,836.00	8,805.00	5,198.00



Contact a Lafert NA Sales Representative for Bevel Helical and Motovariator Dimensional Drawings.

Product Information & Pricing

Performance Rating Tables: Pages 54 & 55
Dimensions: Page 56

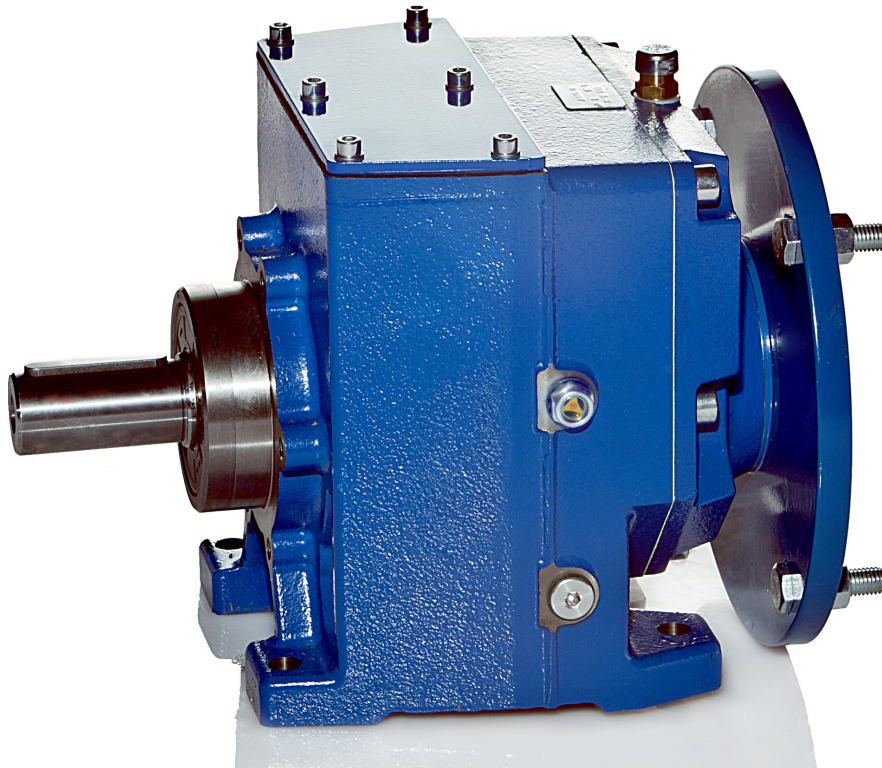

Performance - Up to 336 kW, 12,000 Nm output torque, 466:1 ratio.

Reliability - Gears are case-hardened, quenched and stress relieved.

Versatility - 10 sizes with (3) input versions, multiple mounting positions.

2 Stages of Reduction

Size	Oil	Weight (lbs)	PAM FLANGE		MALE INPUT SHAFT	ADD \$
			MNHL.../2 Price \$	MNHLF.../2 Price \$	NHL.../2 Price \$	
MNHL 16/2	*	20	1,246.00	1,344.00	1,134.00	99.00
MNHL 20/2	*	20	1,246.00	1,344.00	1,134.00	99.00
MNHL 25/2	*	30	1,447.00	1,666.00	1,341.00	219.00
MNHL 30/2	*	50	1,732.00	2,054.00	1,499.00	322.00
MNHL 35/2	**	62	2,365.00	2,688.00	2,247.00	322.00
MNHL 40/2	**	90	3,450.00	3,862.00	3,074.00	412.00
MNHL 50/2	**	120	5,040.00	5,526.00	4,106.00	486.00
MNHL 60/2	**	230	7,864.00	8,413.00	6,971.00	550.00
MNHL 70/2	**	345	10,310.00	10,860.00	10,009.00	550.00
MNHL 90/2	**	508	12,633.00	13,423.00	14,392.00	904.00
MNHL 100/2	**	882	20,552.00	21,740.00	23,241.00	1,188.00

3 Stages of Reduction

Size	Oil	Weight (lbs)	PAM FLANGE		MALE INPUT SHAFT	ADD \$
			MNHL.../3 Price \$	MNHLF.../3 Price \$	NHL.../3 Price \$	
MNHL 25/3	*	35	1,864.00	2,085.00	1,690.00	219.00
MNHL 30/3	*	55	2,161.00	2,482.00	1,769.00	322.00
MNHL 35/3	**	62	2,794.00	3,116.00	2,517.00	322.00
MNHL 40/3	**	95	4,015.00	4,427.00	3,613.00	412.00
MNHL 50/3	**	135	5,719.00	6,205.00	5,184.00	486.00
MNHL 60/3	**	240	8,973.00	9,522.00	8,079.00	550.00
MNHL 70/3	**	390	11,493.00	12,043.00	11,260.00	550.00
MNHL 90/3	**	508	13,384.00	14,290.00	13,947.00	904.00
MNHL 100/3	**	882	23,305.00	24,493.00	24,278.00	1,188.00

* Prelubricated

** Oil available on request at extra cost

Ratings Table (Sizes 20-35)

1750 Input RPM - 1.0 Service Factor

NHL 20				NHL 25				NHL 30				NHL 35			
I	n2	M2	kW	I	n2	M2	kW	I	n2	M2	kW	I	n2	M2	kW
4.32	405	41	1.75	1.9	921	26	2.86	2.25	778	71	5.76	5.12	342	238	8.44
5.13	341	41	1.55	2.77	632	37	2.43	3.08	568	97	5.73	5.97	293	261	7.92
6.1	287	43	1.3	3.75	467	50	2.43	3.63	482	112	5.61	7	250	261	6.76
7.25	240	47	1.18	4.34	403	103	4.28	4.72	371	134	5.16	8.26	212	308	6.76
8.75	200	47	0.98	5.25	333	112	3.85	5.43	322	177	5.43	9.4	186	309	5.96
10.67	164	52	0.89	6.35	275	121	3.45	6.34	276	195	5.58	10.77	162	340	5.72
12.27	143	52	0.77	7.37	237	130	3.21	7.43	236	237	5.79	12.44	141	340	4.96
14.25	123	57	0.72	8.58	204	135	2.85	8.76	200	270	5.58	14.54	120	343	4.28
16.76	104	57	0.62	10.07	174	135	2.43	9.97	176	307	5.58	17.23	102	405	4.26
20.04	87	60	0.54	11.92	147	135	2.06	11.43	153	306	4.86	19.5	90	403	3.75
24.1	72.6	61	0.46	14.31	122	135	1.71	13.21	132	306	4.2	22.3	79	406	3.3
27.43	64	65	0.43	16.32	107	135	1.5	15.43	113	309	3.63	25.85	68	404	2.84
31.24	56	65	0.37	18.8	93	135	1.3	18.29	96	306	3.04	30.49	57	403	2.4
37.94	46	66	0.31	21.94	80	136	1.12	20.69	84.6	306	2.68	36.42	48	404	2.01
43.17	41	65	0.27	26.05	67	135	0.94	23.66	74	307	2.35	40.95	43	403	1.79
49.14	36	65	0.24	31.65	55	135	0.77	27.43	64	308	2.03	45.95	38	403	1.59
				35.29	50	149	0.76	32.35	54	308	1.73	54.56	32	443	1.5
				44.22	40	148	0.61	38.65	45	307	1.44	65.17	27	448	1.27
				49.12	36	149	0.55	43.43	40	305	1.28	78.44	22	447	1.05
				52.1	34	149	0.53	48.76	36	305	1.13	95.49	18	455	0.88
				59.93	29	149	0.46	57.9	30	325	1.04	109.9	16	459	0.77
				69.61	25	148	0.39	69.16	25	327	0.87	127.6	14	467	0.67
				81.87	21	148	0.41	83.24	21	326	0.72	150.1	12	461	0.57
				97.9	18	148	0.28	101.3	17	324	0.59	179.4	10	465	0.48
				117.7	15	148	0.23	116.6	15	327	0.52	215.8	8	464	0.4
				134	13	149	0.21	135.4	13	323	0.44	245.5	7	466	0.35
				152.6	11.5	149	0.18	159.2	11	326	0.38	279.6	5	465	0.31
				185.3	9	149	0.15	190.4	9	325	0.32	339.7	5	465	0.25
				210.9	8	149	0.13	229	8	325	0.26	386.5	5	465	0.22
				240	7	149	0.11	260.6	7	324	0.23	439.9	4	473	0.2
								296.8	6	326	0.2				
								360.5	5	328	0.17				
								410.2	4	326	0.15				
								466.9	4	325	0.13				

n2 = Output Speed M2 = Output Torque (Nm)
 I = Ratio kW = Input kW

Use factor 8.85 to convert Nm to in lbs.

Ratings Table (Sizes 40-70)

1750 Input RPM - 1.0 Service Factor

NHL 40				NHL 50				NHL 60				NHL 70			
I	n2	M2	kW	I	n2	M2	kW	I	n2	M2	kW	I	n2	M2	kW
2.27	771	128	10.24	3.07	570	283	16.73	3.76	465	694	33.48	5.52	317	1858	89.1
3.17	552	180	10.28	3.67	477	339	16.73	5.27	332	1161	39.96	6.53	268	1947	54
3.78	463	230	9.2	4.87	359	449	16.73	5.97	293	1102	33.48	7.42	236	2225	54
4.53	386	223	8.92	5.47	320	558	18.5	6.44	272	1209	34.04	8.86	198	2513	51.4
5.06	346	326	11.68	6.51	269	651	18.15	7.53	232	1352	32.56	10.2	172	2892	51.4
5.96	294	367	11.16	6.72	260	620	16.73	8.38	209	1487	32.19	11.25	156	3260	52.54
7.04	249	419	10.8	7.78	225	772	18	9.92	176	1740	31.82	13.14	133	3352	46.52
8.38	209	456	9.88	8.94	196	884	17.93	11.17	157	1949	31.64	14.67	119	3446	42.6
10.06	174	466	8.4	10.34	169	1022	17.93	13.51	130	1957	26.27	17.55	100	3542	36.6
11.45	153	513	8.12	12.07	845	1023	15.38	15.5	113	1945	22.76	20	88	3606	32.7
13.14	133	522	7.2	14.25	123	1026	13.05	17.99	97	1945	19.61	23.06	76	3699	29.1
15.22	115	520	6.2	16.04	109	1021	11.55	21.19	83	2138	18.3	27	64	3733	25.08
17.85	98	520	5.28	18.22	96	1025	10.2	25.46	69	2150	15.3	32.25	54	3717	20.9
21.3	82	522	4.44	20.9	84	1020	8.85	28.18	62	2136	13.75	35.59	49	3739	19.05
23.45	75	559	4.32	24.31	72	1105	8.25	31.44	56	2137	12.32	39.6	44	3756	17.2
29.05	60	558	3.48	28.76	61	1116	7.04	35.43	49	2139	10.96	44.5	39	3754	15.3
32.78	53	559	3.09	31.54	55	1114	6.4	40.74	43	2135	9.51	48.33	36	3694	14.08
37.96	46	562	2.68	38.77	45	1120	5.24	45.76	38	2136	8.47	57.77	30	3726	11.88
42.21	41	558	2.4	43.59	40	1116	4.64	53.3	33	2146	7.43	66.4	26	3727	10.34
47.4	37	558	2.1	49.93	35	1124	4.16	63.4	28	2138	6.21	76.81	23	3721	8.92
53.09	33	543	1.86	60.43	29	1122	3.42	76.1	23	2136	5.17	89.63	20	3722	7.65
56.28	31	559	1.83	70.83	25	1122	3.42	86.6	20	2144	4.56	105.8	17	3726	6.49
65.23	27	557	1.58	83.55	21	1117	2.46	99.4	18	2135	3.96	119.1	15	3734	5.78
75.97	23	557	1.35	95.1	18	1113	2.2	115.1	15	2137	3.42	135.3	13	3701	5.04
89.11	20	559	1.16	109	16	1119	1.89	135	13	2132	2.91	155.2	11	3708	4.4
105.5	17	555	0.97	125.9	14	1118	1.64	161	11	2154	2.46	180.5	10	3723	3.8
126.6	14	557	0.81	147.1	12	1115	1.4	177.3	10	2117	2.02	213.5	8	3721	3.21
144.4	12	558	0.71	174.4	10	1114	1.18	219.7	8	2125	1.78	234.2	7	3699	2.91
166.4	11	561	0.62	197.3	9	1109	1.04	247.9	7	2139	1.6	287.9	6	3713	2.38
194.2	9	557	0.53	225.6	7.8	1120	0.92	287	6	2140	1.38	323.7	5	3710	2.11
230.5	8	561	0.45	261.5	7	1118	0.79	319.2	5	2137	1.24	370.7	5	3719	1.85
280.1	6	558	0.367	308.5	6	1123	0.67	358.5	5	2134	1.1				
312.3	6	559	0.33	368.5	5	1115	0.56								
391.4	4	559	0.26	414.1	4	1118	0.5								
434.7	4	559	0.24	465	4	1115	0.44								

n2 = Output Speed M2 = Output Torque (Nm)
I = Ratio kW = Input kW

Use factor 8.85 to convert Nm to in lbs.

Dimensions

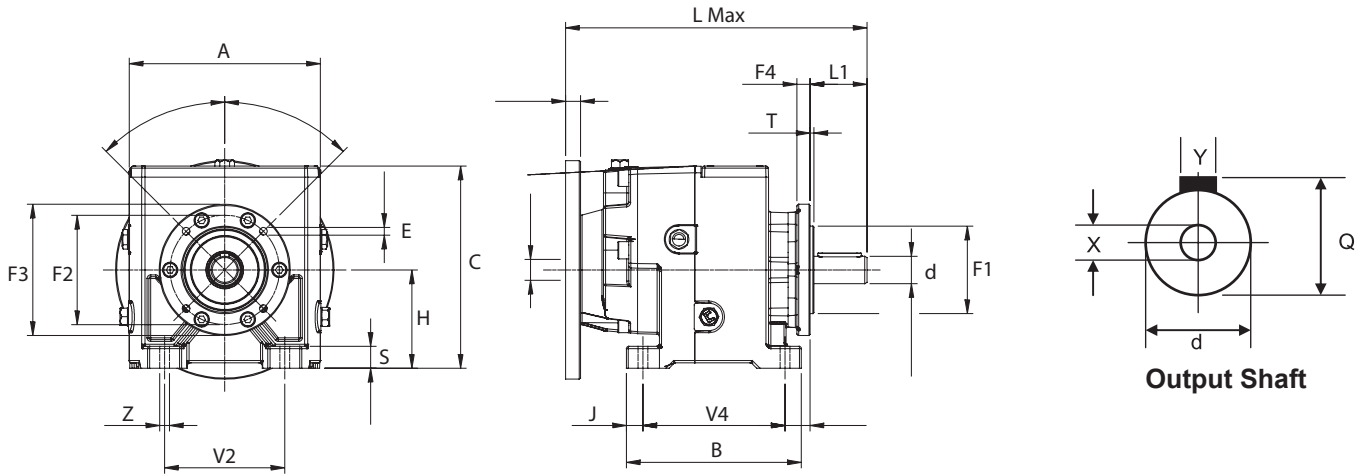

Size	A	B	H	L Max	S	V2	V4	Z	T	L1	C	J	Q	X	Y	d
20/2	140.5	90	75	208	13	110	50	9	1	40	129	30	22.5	M5x12.5	6x6x30	20
25/2	175	160	90	282	20	110	130	9	3.5	50	185	15	28	M8x19	8	25
25/3	175	160	90	282	20	110	130	9	3.5	50	185	15	28	M8x19	8	25
30/2	200	195	115	318	20	135	165	14	3.5	60	241	17.5	33	M8x19	8	30
30/3	200	195	115	318	20	135	165	14	3.5	60	241	17.5	33	M8x19	8	30
35/2	200	195	115	342	20	135	165	14	3.5	70	241	17.5	38	M10x22	10	35
35/3	200	195	115	342	20	135	165	14	3.5	70	241	17.5	38	M10x22	10	35
40/2	220	245	140	425	30	170	205	18	4	80	240	20	43	M10x22	12	40
40/3	220	245	140	425	30	170	205	18	4	80	240	20	43	M10x22	12	40
50/2	261	310	180	500	45	215	260	18	4	100	315	25	53.3	M12x28	14	50
50/3	261	310	180	500	45	215	260	18	4	100	315	25	53.3	M12x28	14	50
60/2	310	364	225	551	55	250	310	22	5	120	380	27	64	M16x36	18	60
60/3	310	364	225	551	55	250	310	22	5	120	380	27	64	M16x36	18	60
70/2	350	440	250	658	65	290	370	26	5	140	413	35	74.5	M16x36	20	70
70/3	350	440	250	658	65	290	370	26	5	140	413	35	74.5	M16x36	20	70
90/2	390	490	315	936	75	340	410	26	5	170	490	40	95	M20x42	25	90
90/3	390	490	315	936	75	340	410	26	5	170	490	40	95	M20x42	25	90
100/2	455	590	345	1058	90	440	500	33	5	210	570	45	106	M20x50	28	100
100/3	455	590	345	1058	90	440	500	33	5	210	570	45	106	M20x50	28	100

Output Flange Dimensions

Size	20	25	30	35	40	50	60	70	90	100	
STYLE 1	F1	80	80	110	110	180	230	250	300	450	
	F2	100	100	130	130	215	265	300	350	500	
	F3	120	120	160	160	250	300	350	400	550	
	F4	7	12	10	10	13	13	18	18	22	25
	E	7	7	9	9	14	18	18	18	18	19
STYLE 2	F1	95	110	130	130	230	250	350	350	-	
	F2	115	130	165	165	265	300	400	400	-	
	F3	140	160	200	200	300	350	450	450	-	
	F4	7	12	10	10	14	13	18	18	22	-
	E	9	9	11.5	11.5	14	18	18	18	18	-
STYLE 3	F1	110	130	180	180	-	-	-	-	-	
	F2	130	165	215	215	-	-	-	-	-	
	F3	160	200	250	250	-	-	-	-	-	
	F4	7	12	10	10	-	-	-	-	-	
	E	9	11.5	14	14	-	-	-	-	-	

Pricing & Dimensions

Type	Execution	Ratios	Weight (lbs)	Price \$
R9	1C / 2A	1:1, 2:1	4	583.00
R9	3C	1:1, 2:1	4	606.00
R14	1C / 2A	1:1, 2:1, 3:1	6	644.00
R14	3C	1:1, 2:1, 3:1	6	673.00
R19	1C / 2A	1:1, 2:1, 3:1	12	1241.00
R19	3C	1:1, 2:1, 3:1	12	1263.00
R24	1C / 2A	1:1, 2:1, 3:1	14	1241.00
R24	3C	1:1, 2:1, 3:1	14	1267.00

Execution Options

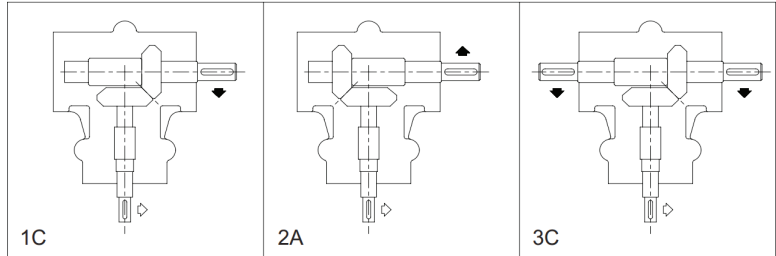

- Maximum power of 7.9 kW
- Output torque from 2 Nm to 35 Nm
- Reduction ratios available 1:1, 2:1, 3:1

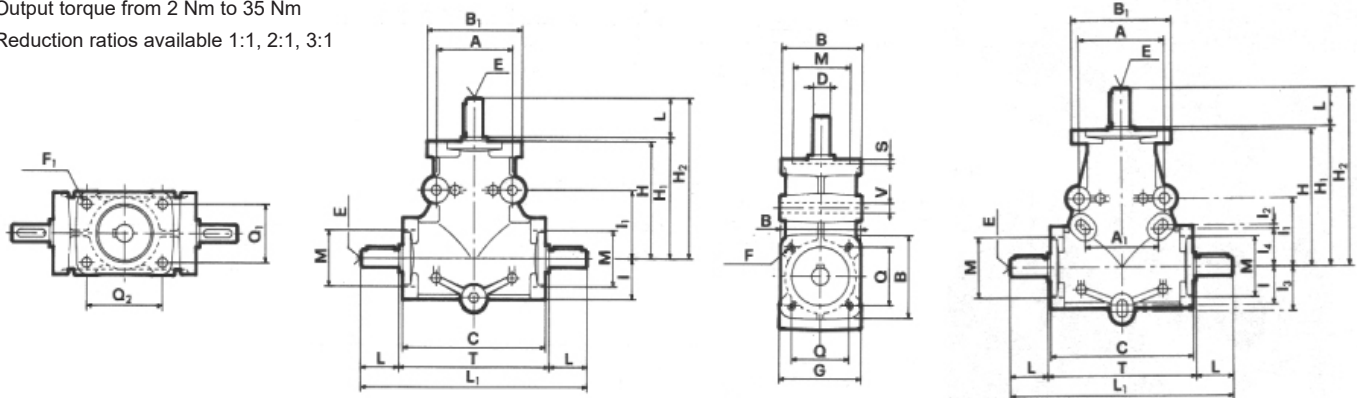

Size	A	A ₁	C	G	H	H ₁	H ₂	I	I ₁	I ₂	I ₃	I ₄	L ₁	T	V	B	B ₁	F	F ₁	M _{h7}	Q	Q ₁	Q ₂	S	D _{h7}	E	L
R 9	40	-	75	43	60	61	81	20	35	-	-	-	117	77	5	42	50	M4	5	30	30	30	40	2.5	9	M4	20
R 14	60	-	110	70	90	91	121	32	63	-	-	-	172	112	9	64	64	M8	M8	47	46	46	46	4	14	M5	30
R 19	90	77.5	150	86	140	141	181	38	70	5	45	38	232	152	11	84	105	M10	10.5	62	60	60	80	5	19	M8	40
R 24	90	77.5	150	86	140	141	191	38	70	5	45	38	252	152	11	84	105	M10	10.5	62	60	60	80	5	24	M8	50

NRG - Planetary Gearboxes

Overview



Base Mount

High Modularity

- Modular design with compact subgroups for easy ratio replacement (up to 4 reduction stages)

High Versatility

- 7 sizes with 4 input & 4 output configurations
- 2 Output support connections:
 - SM (Standard)
 - SMR (reinforced for High load)
- 3 Options of mounting positions:
 - Direct Couple
 - Foot Mount
 - Flange Mount



Output Flange

High Performances

- Maximum input power 45 kW
- Maximum torque of over 30,000 Nm
- Ratios up to 4,066:1

High Reliability

- Strengthened casing for heavy duty applications
- High resistant gears with oversized bearings
- Superior sealing for leak prevention

6-LEAD MOTOR CONNECTION Δ / Y

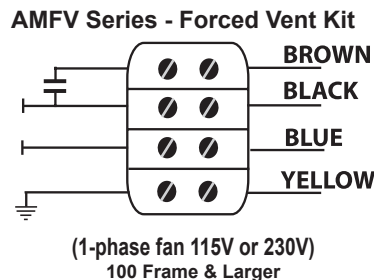
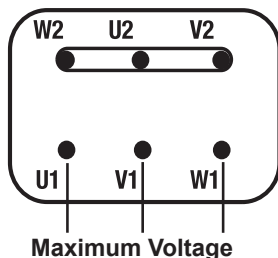
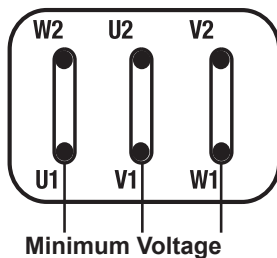

9-LEAD MOTOR CONNECTION YY / Y

6 Post Block

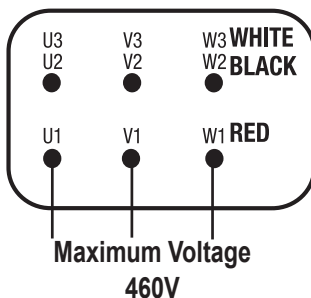
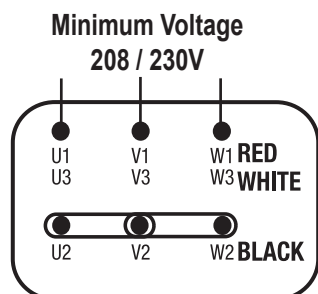

9 Post Block

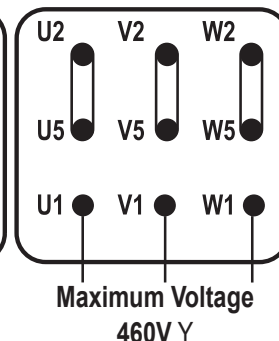
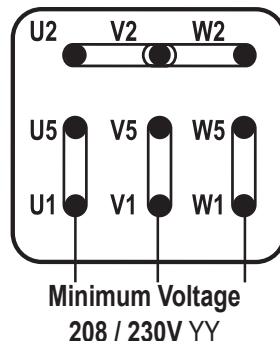

2 SPEED (1 WINDING) - 2/4 & 4/8 POLES

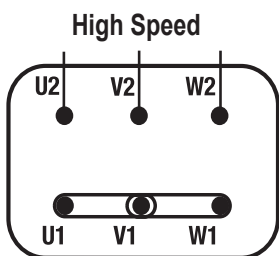
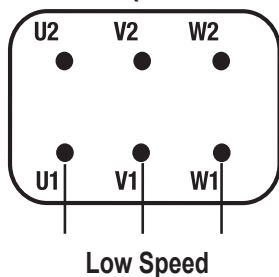

2 SPEED (2 WINDINGS) - 2/8, 4/6 & 6/8 POLES

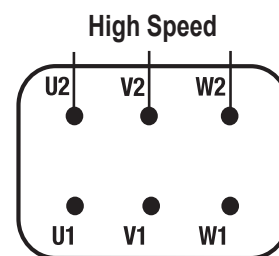
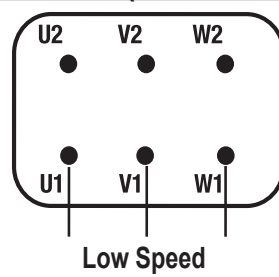

MS Type - Compact Brake Motor

D.C. Brake Coil

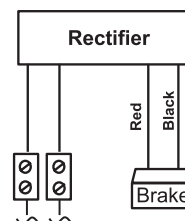
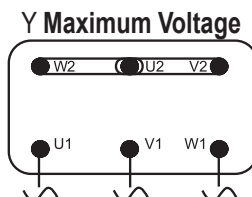
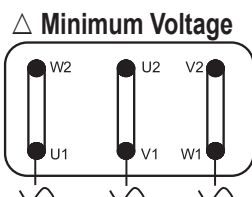
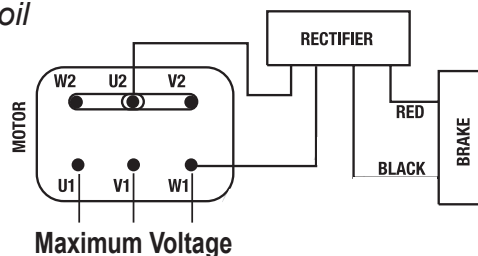
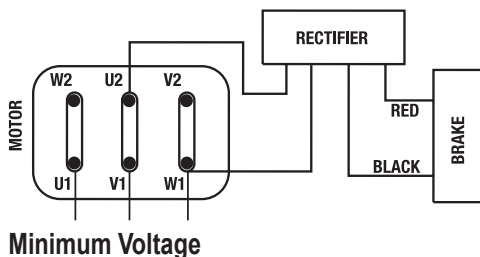

MS brake coils may be wired separately by removing the leads from the motor block and connecting to an alternate/separate power source. Alternate voltage coils are available. Always check to ensure incoming voltage matches the coil voltage.

TERMS AND CONDITIONS OF SALE

PRICES: Prices shown are F.O.B. Mississauga, Ontario, Canada. All taxes are extra, where applicable. Prices are subject to confirmation at the time of ordering.

PAYMENT TERMS: Payment is due 30 days from the date of shipment for credit approved accounts. 2% per month finance charge will be added to any overdue account not paid after 30 days or as allowed by law. Product will remain the property of LAFERT NORTH AMERICA INC until complete payment had been made by the purchaser.

CLAIM: Claims for shortage or damaged goods for any collect shipment must be made to the transportation company as risk passes to the customer at the point of F.O.B. Claims for shortage or damaged goods for any prepaid shipment will be made to the transportation company as risk stands with the shipper at the point of F.O.B.

WARRANTY: No warranty changes or credits will be issued without prior approval from Lafert NA. Lafert Motors, SITI Gear Reducers and Sacemi Pumps are covered by a one-year warranty from date of sale or 18 months from date of manufacture, whichever comes first. This warranty is against defects in manufacture or defective material only. The seller will, at their option, either replace or repair the defective units. Warranty does not apply to improper storage, improper installation or use, modification or repair without our authorization and any other fault beyond our control.

SELLER LIMITATION: The seller makes no warranties respecting the suitability or fitness of these motors for any particular purpose or use. The buyer shall not, in any event, be entitled to, and the seller shall not be liable for loss of profit, direct or indirect and incidental or consequential damages of any nature. Buyer recovery from seller for any claim shall not exceed the buyer's purchase price for the product, irrespective of the claim whether in contract warranty or otherwise. No liability will be accepted for field service, removal, replacement, inspection, freight or travel charges unless previously authorized by LAFERT NORTH AMERICA INC.

RETURN GOODS: You must obtain prior authorization before returning any product. Product being returned must be properly packaged against breakage and be shipped freight pre-paid to LAFERT NORTH AMERICA INC or its authorized repair depot.





HIGH PERFORMANCE
MOTORS & DRIVES

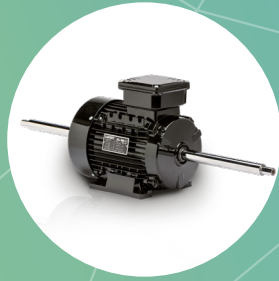

CUSTOM BUILT
MOTORS



BRAKE
MOTORS



BRUSHLESS SERVO
MOTORS



GEARBOXES



STAINLESS STEEL
MOTORS

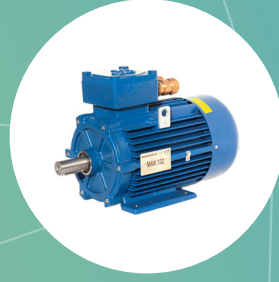

EXPLOSION PROOF
MOTORS



COOLANT PUMPS



Member of Sumitomo Drive Technologies

1-800-661-6413

Lafert North America Inc.
5620 Kennedy Road - Mississauga
Ontario L4Z 2A9
Canada

Phone 905-629-1939 - Fax 905-629-2852
lna.info@shi-g.com - www.lafertna.com

Regional Warehouses

Canada
Alberta - Ontario

USA
California - Indiana - Pennsylvania
South Carolina - Texas

